

ASME B30.2-2001
(Revision of ASME B30.2-1996)

**OVERHEAD AND
GANTRY CRANES
(TOP RUNNING BRIDGE,
SINGLE OR
MULTIPLE GIRDER,
TOP RUNNING
TROLLEY HOIST)**

AN AMERICAN NATIONAL STANDARD



The American Society of
Mechanical Engineers



A N A M E R I C A N N A T I O N A L S T A N D A R D

**OVERHEAD AND
GANTRY CRANES
(TOP RUNNING BRIDGE,
SINGLE OR
MULTIPLE GIRDER,
TOP RUNNING
TROLLEY HOIST)**

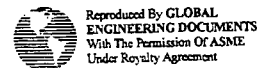

**ASME B30.2-2001
(Revision of ASME B30.2-1996)**

SAFETY STANDARD FOR CABLEWAYS, CRANES, DERRICKS, HOISTS, HOOKS, JACKS, AND SLINGS

Date of Issuance: January 25, 2002

The next edition of this Standard is scheduled for publication in 2006. There will be no addenda issued to this Edition.

ASME issues written replies to inquiries concerning interpretations of technical aspects of this Standard.

ASME is the registered trademark of The American Society of Mechanical Engineers.

This code or standard was developed under procedures accredited as meeting the criteria for American National Standards. The Standards Committee that approved the code or standard was balanced to assure that individuals from competent and concerned interests have had an opportunity to participate. The proposed code or standard was made available for public review and comment that provides an opportunity for additional public input from industry, academia, regulatory agencies, and the public-at-large.

ASME does not "approve," "rate," or "endorse" any item, construction, proprietary device, or activity.

ASME does not take any position with respect to the validity of any patent rights asserted in connection with any items mentioned in this document, and does not undertake to insure anyone utilizing a standard against liability for infringement of any applicable letters patent, nor assume any such liability. Users of a code or standard are expressly advised that determination of the validity of any such patent rights, and the risk of infringement of such rights, is entirely their own responsibility.

Participation by federal agency representative(s) or person(s) affiliated with industry is not to be interpreted as government or industry endorsement of this code or standard.

ASME accepts responsibility for only those interpretations of this document issued in accordance with the established ASME procedures and policies, which preclude the issuance of interpretations by individuals.

No part of this document may be reproduced in any form,
in an electronic retrieval system or otherwise,
without the prior written permission of the publisher.

The American Society of Mechanical Engineers
Three Park Avenue, New York, NY 10016-5990

Copyright © 2002 by
THE AMERICAN SOCIETY OF MECHANICAL ENGINEERS
All Rights Reserved
Printed in U.S.A.

CONTENTS

Foreword	v
Committee Roster	vii
Summary of Changes	ix
Introduction	1
General	1
Section I Scope	2
Section II Purpose	2
Section III Interpretations	2
Section IV New and Existing Installations	2
Section V Mandatory and Advisory Rules	3
Section VI Metric Conversions	3
Chapter 2-0 Scope, Definitions, and References	4
Section 2-0.1 Scope of B30.2	4
Section 2-0.2 Definitions	4
Section 2-0.3 References	9
Chapter 2-1 General Construction and Installation	10
Section 2-1.1 Markings	10
Section 2-1.2 Clearances	10
Section 2-1.3 General Construction — Runways and Supporting Structure	11
Section 2-1.4 Crane Construction	11
Section 2-1.5 Cabs — Normal or Skeleton (if Provided)	11
Section 2-1.6 Lubrication	12
Section 2-1.7 Service Platforms (Footwalks)	12
Section 2-1.8 Stops and Bumpers	13
Section 2-1.9 Rail Sweeps	13
Section 2-1.10 Guards for Moving Parts	14
Section 2-1.11 Truck Frame Drop	14
Section 2-1.12 Brakes and Braking Means	14
Section 2-1.13 Electrical Equipment	15
Section 2-1.14 Hoisting Equipment	19
Section 2-1.15 Warning Devices or Means for a Crane With a Power-Traveling Mechanism	20
Section 2-1.16 Manual	20
Chapter 2-2 Inspection, Testing, and Maintenance	21
Section 2-2.1 Inspection	21
Section 2-2.2 Testing	22
Section 2-2.3 Maintenance	22
Section 2-2.4 Rope Inspection, Replacement, and Maintenance	23
Chapter 2-3 Operation	26

Section 2-3.1	Qualifications for and Conduct of Operators	26
Section 2-3.2	Handling the Load	27
Section 2-3.3	Signals	30
Section 2-3.4	Miscellaneous	30
Section 2-3.5	Crane Lockout/Tagout	30

Figures

1	Cantilever Gantry Crane	5
2	Gantry Crane	6
3	Overhead Crane	6
4	Semigantry Crane	6
5	Wall Crane	7
6	Recommended Arrangement of Controllers or Master Switches (Three-Motor Crane)	17
7	Recommended Arrangement of Controllers or Master Switches (Four-Motor Crane)	17
8	Recommended Arrangement of Controllers (Pendant Push-Button Station Arrangement)	18
9	Recommended Arrangement of Controllers (Radio Crane Control Transmitter Lever Arrangement)	18
10	Standard Hand Signals for Controlling Overhead and Gantry Cranes	28

FOREWORD

This American National Standard, Safety Standard for Cableways, Cranes, Derricks, Hoists, Hooks, Jacks, and Slings, has been developed under the procedures accredited by the American National Standards Institute (ANSI, formerly the United States of America Standards Institute). This Standard had its beginning in December 1916 when a Code of Safety Standards for Cranes, prepared by an ASME Committee on the Protection of Industrial Workers, was presented to the annual meeting of the ASME.

Meetings and discussions regarding safety on cranes, derricks, and hoists were held from 1920 to 1925, involving the ASME Safety Code Correlating Committee, the Association of Iron and Steel Electrical Engineers, the American Museum of Safety, the American Engineering Standards Committee (later changed to American Standards Association and subsequently to the USA Standards Institute), the Department of Labor — State of New Jersey, the Department of Labor and Industry — State of Pennsylvania, and the Locomotive Crane Manufacturers Association. On June 11, 1925, the American Engineering Standards Committee approved the ASME Safety Code Correlating Committee's recommendation and authorized the project with the U.S. Department of the Navy, Bureau of Yards and Docks, and ASME as sponsors.

In March 1926, invitations were issued to 50 organizations to appoint representatives to a Sectional Committee. The call for organization of this Sectional Committee was sent out October 2, 1926, and the Committee organized November 4, 1926, with 57 members representing 29 national organizations. The Safety Code for Cranes, Derricks, and Hoists, ASA B30.2-1943, was created from the eight-page document referred to in the first paragraph. This document was reaffirmed in 1952 and widely accepted as a safety standard.

Due to changes in design, advancement in techniques, and general interest of labor and industry in safety, the Sectional Committee, under the joint sponsorship of ASME and the Naval Facilities Engineering Command, U.S. Department of the Navy, was reorganized as an American National Standards Committee on January 31, 1962, with 39 members representing 27 national organizations.

The format of the previous code was changed so that separate volumes (each complete as to construction and installation; inspection, testing, and maintenance; and operation) would cover the different types of equipment included in the scope of B30.

In 1982, the Committee was reorganized as an Accredited Organization Committee, operating under procedures developed by ASME and accredited by the American National Standards Institute.

This Standard presents a coordinated set of rules that may serve as a guide to government and other regulatory bodies and municipal authorities responsible for the guarding and inspection of the equipment falling within its scope. The suggestions leading to accident prevention are given both as mandatory and advisory provisions; compliance with both types may be required by employers of their employees.

In case of practical difficulties, new developments, or unnecessary hardship, the administrative or regulatory authority may grant variances from the literal requirements or permit the use of other devices or methods, but only when it is clearly evident that an equivalent degree of protection is thereby secured. To secure uniform application and interpretation of this Standard, administrative or regulatory authorities are urged to consult the B30

Committee, in accordance with the format described in Section III of the Introduction, before rendering decisions on disputed points.

This volume of the Standard, which was approved by the B30 Committee and by ASME, was approved by ANSI and designated as an American National Standard on September 19, 2001.

Safety codes and standards are intended to enhance public safety. Revisions result from committee consideration of factors such as technological advances, new data, and changing environmental and industrial needs. Revisions do not imply that previous editions were inadequate.

ASME B30 COMMITTEE

Safety Standards for Cableways, Cranes, Derricks, Hoists, Hooks, Jacks, and Slings

(The following is the roster of the Committee at the time of approval of this Standard.)

OFFICERS

P. S. Zorich, *Chair*
B. D. Closson, *Vice Chair*
J. D. Wendler, *Secretary*

COMMITTEE PERSONNEL

R. E. Bluff, Mingus Constructors, Inc.
R. J. Bolen, E. I. Dupont
A. D. Brown, Kenney Construction Co.
T. A. Christensen, Alliance of American Insurers/Liberty Mutual Insurance
M. W. Mills, *Alternate*, Liberty Mutual Group
B. D. Closson, NACB Technical Service
T. L. Blanton, *Alternate*, NACB Group, Inc.
J. P. Colletti, John P. Colletti & Associates
R. A. Dahlin, Walker Magnetic Group
J. W. Downs, Jr., *Alternate*, Downs Crane and Hoist Co.
D. W. Eckstine, Grove Worldwide
R. H. Fowler, U.S. Department of the Air Force
J. L. Franks, Consultant
R. C. Slater, *Alternate*, McKay International Engineering
N. C. Hargreaves, Power Crane & Shovel Association/Terex Corp.
D. G. Quinn, *Alternate*, Linkbelt Construction Equipment
J. J. Headley, Crane Institute of America
R. M. Parnell, *Alternate*, Industrial Training International
G. F. Hoffa, Forging Industry Association
E. K. Marburg, *Alternate*, Columbus McKinnon Corp.
C. L. Huneycutt, Associated General Contractors of America/J. A. Jones Construction Co.
W. P. Rollins, *Alternate*, J. A. Jones Construction Co.
C. W. Ireland, Amclyde Engineered Products
L. S. Johnson, American Equipment Co.
G. L. Owens, *Alternate*, Granite Construction, Inc.
H. G. Leidich, Ingersoll-Rand
J. T. Perkins, *Alternate*, Ingersoll-Rand
C. Lucas, The Crosby Group
P. A. Boeckman, *Alternate*, The Crosby Group
L. D. Means, Wire Rope Technical Board/Wire Rope Corp. of America, Inc.
K. Miller, Steel Plate Fabricators Association/Chicago Bridge and Iron, Co.
D. W. Smith, *Alternate*, Chicago Bridge and Iron Co.
R. R. Reisinger, FKI Industries, Inc.
J. L. Gordon, *Alternate*, FKI Industries, Inc.
J. E. Richardson, U.S. Department of the Navy

J. W. Rowland III, Association of Iron and Steel Engineers/Bethlehem Steel Corp.
E. E. Rudy, U.S. Department of the Navy
J. C. Ryan, BOH Bros. Construction Co.
H. E. Livermore, *Alternate*, Association of Construction Equipment Managers/Bechtel Leasing Service, Inc.
D. Sayenga, Associated Wire Rope Fabricators
D. J. Bishop, *Alternate*, Bishop Lifting Products, Inc.
H. I. Shapiro, Specialized Carriers and Rigging Association/Howard I. Shapiro & Associates
R. M. Kohner, *Alternate*, Landmark Engineering Service
W. J. Smith, U.S. Department of Labor, OSHA
S. C. Buck, *Alternate*, International Union of Operating Engineers, Local 150
A. R. Toth, Morris Material Handling
S. J. McCormick, *Alternate*, Morris Material Handling
B. E. Weir, Jr., National Erectors Association/Norris Brothers Co., Inc.
S. Conant, *Alternate*, Conant Crane Rental Co.
J. D. Wendler, The American Society of Mechanical Engineers
R. C. Wild, U.S. Army Corps of Engineers
S. G. Testerman, *Alternate*, U.S. Army Corps of Engineers
D. N. Wolff, National Crane Corp.
P. S. Zorich, RZP International Ltd.

HONORARY MEMBERS

J. M. Klibert, Lift-All Co, Inc.
T. S. McKosky, Consultant
R. W. Parry, Consultant

B30.2 SUBCOMMITTEE PERSONNEL

R. R. Reisinger, *Chair*
A. R. Toth, *Vice Chair*
T. W. Elmy, Alcoa, Inc.
R. H. Fowler, U.S. Department of the Air Force
J. L. Franks, Consultant
W. R. Gedgard, Navy Crane Center
J. L. Gordon, FKI Industries, Inc.
J. D. Kerr, U.S. Army Corps of Engineers
L. D. Means, Wire Rope Corp. of America
R. H. Reus, P & H Material Handling
J. W. Rowland, Bethlehem Steel Corp.
G. V. Stanic, Globex Corp.

ASME B30.2-2001 SUMMARY OF CHANGES

Following approval by the ASME B30 Committee, and after public review, ASME B30.2-2001 was approved by the American National Standards Institute on September 19, 2001.

The 2001 edition of ASME B30.2 includes editorial changes, revisions, and corrections introduced in B30.2a-1997, B30.2b-1998, and B30.2c-2001, as well as the following changes identified by a margin note, (01).

<i>Page</i>	<i>Location</i>	<i>Change</i>
1	General	List of B30 Standards updated
9	Section 2-0.3	Updated
11	2-1.3.2(a)(1)	Revised
	2-1.3.2(a)(4)	Revised
	2-1.4.2	Revised
	2-1.4.3	Revised
15	2-1.12.5	Revised

SPECIAL NOTE

The interpretations to ASME B30.2 are included in this edition as a separate section for the user's convenience.

SAFETY STANDARD FOR CABLEWAYS, CRANES, DERRICKS, HOISTS, HOOKS, JACKS, AND SLINGS

INTRODUCTION

1) General

This Standard is one of a series of safety standards on various subjects which have been formulated under the general auspices of the American National Standards Institute. One purpose of the Standard is to serve as a guide to governmental authorities having jurisdiction over subjects within the scope of the Standard. It is expected, however, that the Standard will find a major application in industry, serving as a guide to manufacturers, purchasers, and users of the equipment.

For the convenience of the user, the Standard has been divided into separate volumes:

- B30.1 Jacks
- B30.2 Overhead and Gantry Cranes (Top Running Bridge, Single or Multiple Girder, Top Running Trolley Hoist)
- B30.3 Construction Tower Cranes
- B30.4 Portal, Tower, and Pillar Cranes
- B30.5 Mobile and Locomotive Cranes
- B30.6 Derricks
- B30.7 Base Mounted Drum Hoists
- B30.8 Floating Cranes and Floating Derricks
- B30.9 Slings
- B30.10 Hooks
- B30.11 Monorails and Underhung Cranes
- B30.12 Handling Loads Suspended From Rotorcraft
- B30.13 Storage/Retrieval (S/R) Machines and Associated Equipment
- B30.14 Side Boom Tractors
- B30.15 Mobile Hydraulic Cranes
Note: B30.15-1973 has been withdrawn.
The revision of B30.15 is included in the latest edition of B30.5.
- B30.16 Overhead Hoists (Underhung)
- B30.17 Overhead and Gantry Cranes (Top Running Bridge, Single Girder, Underhung Hoist)
- B30.18 Stacker Cranes (Top or Under Running Bridge, Multiple Girder With Top or Under Running Trolley Hoist)
- B30.19 Cableways
- B30.20 Below-the-Hook Lifting Devices

- B30.21 Manually Lever Operated Hoists
- B30.22 Articulating Boom Cranes
- B30.23 Personnel Lifting Systems
- B30.24 Container Cranes¹
- B30.25 Scrap and Material Handlers
- B30.26 Rigging Hardware¹
- B30.27 Material Placement Systems¹
- B30.28 Balance-Lifting Units¹

If adopted for governmental use, the references to other national codes and standards in the specific volumes may be changed to refer to the corresponding regulations of the governmental authorities.

The use of cableways, cranes, derricks, hoists, hooks, jacks, and slings is subject to certain hazards that cannot be met by mechanical means but only by the exercise of intelligence, care, and common sense. It is therefore essential to have personnel involved in the use and operation of equipment who are competent, careful, physically and mentally qualified, and trained in the safe operation of the equipment and the handling of the loads. Serious hazards are overloading, dropping or slipping of the load caused by improper hitching or slinging, obstructing the free passage of the load, and using equipment for a purpose for which it was not intended or designed.

The Standards Committee fully realizes the importance of proper design factors, minimum or maximum sizes, and other limiting dimensions of wire rope or chain and their fastenings, sheaves, sprockets, drums, and similar equipment covered by the Standard, all of which are closely connected with safety. Sizes, strengths, and similar criteria are dependent on many different factors, often varying with the installation and uses. These factors depend on the condition of the equipment or material; on the loads; on the acceleration or speed of the ropes, chains, sheaves, sprockets, or drums; on the type of attachments; on the number, size, and arrangement of sheaves or other parts; on environmental conditions causing corrosion or wear; and on many

¹ B30.24, B30.26, B30.27, and B30.28 are in the developmental stage.

variables that must be considered in each individual case. The rules given in the Standard must be interpreted accordingly, and judgment used in determining their application.

The Standards Committee will be glad to receive criticisms of this Standard's requirements and suggestions for its improvement, especially those based on actual experience in application of the rules. Suggestions for changes to the Standard should be submitted to the Secretary of the B30 Committee, ASME, Three Park Avenue, New York, NY 10016-5990, and should be in accordance with the following format:

(a) cite the specific paragraph designation of the pertinent volume;

(b) indicate the suggested change (addition, deletion, revision, etc.);

(c) briefly state the reason and/or evidence for the suggested change; and

(d) submit suggested changes to more than one paragraph in the order that the paragraphs appear in the volume.

The B30 Committee will consider each suggested change in a timely manner in accordance with its procedures.

Section I: Scope

This Standard applies to the construction, installation, operation, inspection, and maintenance of jacks; power-operated cranes, monorails, and crane runways; power-operated and manually operated derricks and hoists; lifting devices, hooks, and slings; and cableways.

This Standard does not apply to track and automotive jacks, railway or automobile wrecking cranes, shipboard cranes, shipboard cargo-handling equipment, well-drilling derricks, skip hoists, mine hoists, truck body hoists, car or barge pullers, conveyors, excavating equipment, or equipment coming within the scope of the following Committees: A10, A17, A90, A92, A120, B20, B56, and B77.

Section II: Purpose

This Standard is designed to:

(a) guard against and minimize injury to workers, and otherwise provide for the protection of life, limb, and property by prescribing safety requirements;

(b) provide direction to owners, employers, supervisors, and others concerned with, or responsible for, its application; and

(c) guide governments and other regulatory bodies

in the development, promulgation, and enforcement of appropriate safety directives.

Section III: Interpretations

Upon request, the B30 Committee will render an interpretation of any requirement of the Standard. Interpretations can only be rendered in response to a written request sent to the Secretary of the B30 Committee, ASME, Three Park Avenue, New York, NY 10016-5990.

The request for interpretation should be clear and unambiguous. It is further recommended that the inquirer submit his request utilizing the following format.

Subject: Cite the applicable paragraph number(s) and provide a concise description.

Edition: Cite the applicable edition of the pertinent volume for which the interpretation is being requested.

Question: Phrase the question as a request for an interpretation of a specific requirement suitable for general understanding and use, not as a request for approval of a proprietary design or situation. The inquirer may also include any plans or drawings which are necessary to explain the question; however, they should not contain any proprietary names or information.

Requests that are not in this format will be rewritten in this format by the Committee prior to being answered, which could change the intent of the original request.

ASME procedures provide for reconsideration of any interpretation when or if additional information which might affect an interpretation is available. Further, persons aggrieved by an interpretation may appeal to the cognizant ASME Committee or Subcommittee. ASME does not "approve," "certify," "rate," or "endorse" any item, construction, proprietary device, or activity.

Section IV: New and Existing Installations

(a) *Effective Date.* The effective date of this volume for the purpose of defining new and existing installations shall be 1 year after its date of issuance.

(b) *New Installations.* Construction, installation, inspection, testing, maintenance, and operation of equipment manufactured and facilities constructed after the

OVERHEAD AND GANTRY CRANES

ASME B30.2-2001

effective date of this volume shall conform with the mandatory requirements of this volume.

(c) *Existing Installations.* Inspection, testing, maintenance, and operation of equipment manufactured and facilities constructed prior to the effective date of this volume shall be done, as applicable, in accordance with the requirements of this volume.

It is not the intent of this volume to require retrofitting of existing equipment. However, when an item is being modified, its performance requirement shall be reviewed relative to the current volume. If the performance differs substantially, the need to meet the current requirement shall be evaluated by a qualified person selected by the owner (user). Recommended changes shall be made by the owner (user) within 1 year.

Section V: Mandatory and Advisory Rules

Mandatory rules of this volume are characterized by use of the word *shall*. If a provision is of an advisory nature, it is indicated by use of the word *should* and is a recommendation to be considered, the advisability of which depends on the facts in each situation.

Section VI: Metric Conversions

The values stated in U.S. Customary units are to be regarded as the standard.

ASME B30.2-2001

OVERHEAD AND GANTRY CRANES

(TOP RUNNING BRIDGE, SINGLE OR MULTIPLE GIRDER, TOP RUNNING TROLLEY HOIST)

CHAPTER 2-0

SCOPE, DEFINITIONS, AND REFERENCES

Section 2-0.1: Scope of B30.2

Within the general scope defined in Section I, B30.2 applies to overhead and gantry cranes with a top running bridge of single or multiple girder construction, utilizing a top running trolley, including polar, semigantry, cantilever gantry, wall cranes, and others having the same fundamental characteristics. This volume includes both power-driven and hand-operated equipment. These cranes are grouped because they all have top running trolleys and similar travel characteristics.

Section 2-0.2: Definitions

abnormal operating conditions: environmental conditions that are unfavorable, harmful, or detrimental to or for the operation of a crane, such as excessively high or low ambient temperatures, exposure to adverse weather, corrosive fumes, dust-laden or moisture-laden atmospheres, and hazardous locations.

administrative or regulatory authority: governmental agency or, in the absence of governmental jurisdiction, the employer.

appointed: assigned specific responsibilities by the employer or the employer's representative.

authorized: appointed by a duly constituted administrative or regulatory authority.

auxiliary hoist: supplemental hoisting unit usually of lower load rating and higher speed than the main hoist.

boom (of overhead cranes): a horizontal member mounted on the trolley to permit hoisting and lowering the load at a point other than directly under the hoist drum or trolley.

boom (of gantry cranes): an extension of the trolley runway that may be raised or retracted to obtain clearance for gantry travel.

brake: a device, other than a motor, used for retarding or stopping motion by friction or power means.

brake, holding: a friction brake for a hoist that is automatically applied and prevents motion when power to the brake is off.

brake, mechanical load: an automatic type of friction brake used for controlling loads in a lowering direction. This unidirectional device requires torque from the motor to lower a load but does not impose any additional load on the motor when lifting a load.

braking means: a method or device used for stopping/holding motion by friction or power.

braking, control: a method of controlling speed by removing energy from the moving body or by imparting energy in the opposite direction.

braking, countertorque (plugging): a method of controlling speed by reversing the motor line voltage polarity or phase sequence to develop torque in the direction opposite the rotation of the motor.

braking, dynamic: a method of controlling speed by using the motor as a generator, with the energy being dissipated in resistors.

braking, eddy current: a method of controlling or reducing speed by means of an electrical induction load brake.

braking, emergency: a method of decelerating a drive when power is not available. The braking effort may be established as a result of action by the operator, or automatically when power to the drive is interrupted.

OVERHEAD AND GANTRY CRANES

ASME B30.2-2001

braking, hydraulic: a method of controlling or reducing speed by means of displacement of a liquid.

braking, mechanical: a method of controlling or reducing speed by friction.

braking, pneumatic: a method of controlling or reducing speed by means of compressed gas.

braking, regenerative: a method of controlling speed in which the electrical energy generated by the motor is fed back into the power system.

braking, service: a method to decelerate crane motion during normal operation.

bridge: that part of a crane consisting of one or more girders, trucks, end ties, footwalks, and drive mechanism, which carries the trolley or trolleys.

bridge travel: the crane movement in a direction parallel to the crane runway.

bumper (buffer): a device for reducing impact when a moving crane or trolley reaches the end of its permitted travel, or when two moving cranes or trolleys come into contact. This device may be attached to the bridge, trolley, or runway stop.

cab: the operator's compartment on a crane.

cab, normal: operator's compartment used for controlling a cab-operated crane.

cab, skeleton: operator's compartment used for occasional cab operation of a normally floor- or remote-operated crane.

cantilever frame: a structural member that supports the trolley of a wall crane.

clearance: distance from any part of the crane to the nearest obstruction.

collectors, current: contacting devices for collecting current from runway or bridge conductors.

conductors, bridge: the electrical conductors located along the bridge structure of a crane that transmit control signals and power to the trolley(s).

conductors, runway (main): the electrical conductors located along a crane runway that transmit control signals and power to the crane.

controller: a device, or group of devices, that serves to govern, in a predetermined manner, the power delivered directly to the apparatus to which it is connected.

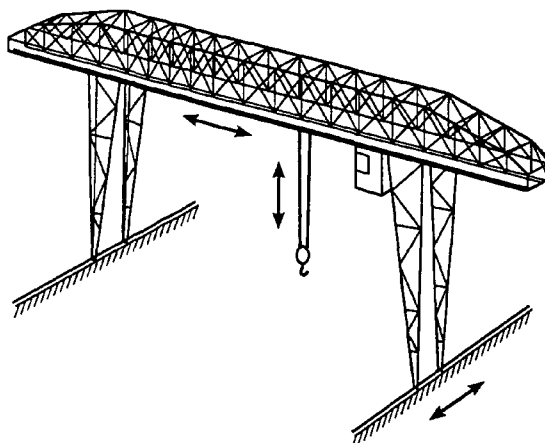

FIG. 1 CANTILEVER GANTRY CRANE

controller, manual: a controller having all of its basic functions performed by devices that are operated by hand.

controller, spring-return: a controller that, when released, will return automatically to a neutral (off) position.

control panel: an assembly of components (magnetic, static, hydraulic, pneumatic, etc.) that governs the flow of power to or from a motor or other equipment in response to signals from a master switch, push-button station, remote control, automatic program control, or other similar device.

crane: a machine for lifting and lowering a load and moving it horizontally, with the hoisting mechanism being an integral part of the machine.

crane, automatic: a crane which, when activated, operates through a preset cycle or cycles.

crane, cab-operated: a crane whose movements are controlled by an operator through the use of controllers located in a cab that is attached to the crane.

crane, cantilever gantry: a gantry or semigantry crane in which the bridge girders or trusses extend transversely beyond the crane runway on one or both sides (see Fig. 1).

crane, floor-operated: a crane whose movements are controlled by an operator through the use of controllers contained in a pendant station suspended from the crane.

crane, gantry: a crane similar to an overhead crane except that the bridge for carrying the trolley or trolleys

ASME B30.2-2001

OVERHEAD AND GANTRY CRANES

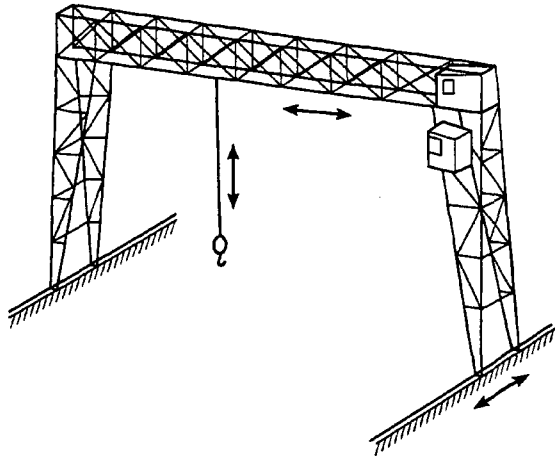

FIG. 2 GANTRY CRANE

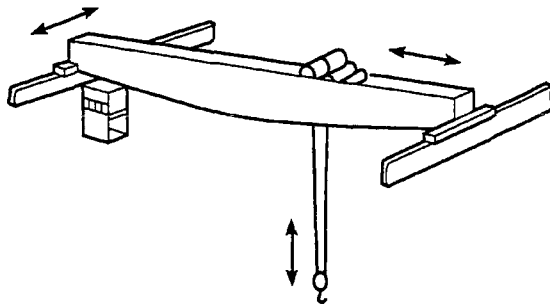

FIG. 3 OVERHEAD CRANE

is rigidly supported on two or more legs running on fixed rails or other runway (see Fig. 2).

crane, molten-material-handling: an overhead crane used for transporting or pouring molten material.

crane, manually operated: a crane whose hoist mechanism is driven by pulling an endless chain, or whose travel mechanism is driven in the same manner or by manually moving the load or hook.

crane, outdoor: an overhead or gantry crane that operates outdoors and for which provisions are not available for storage in an area that provides protection to the crane from weather conditions. An indoor crane that may operate outdoors on a periodic basis is not classified as an outdoor crane.

crane, overhead: a crane with a single or multiple girder movable bridge carrying a movable or fixed hoisting mechanism and traveling on an overhead fixed runway structure (see Fig. 3).

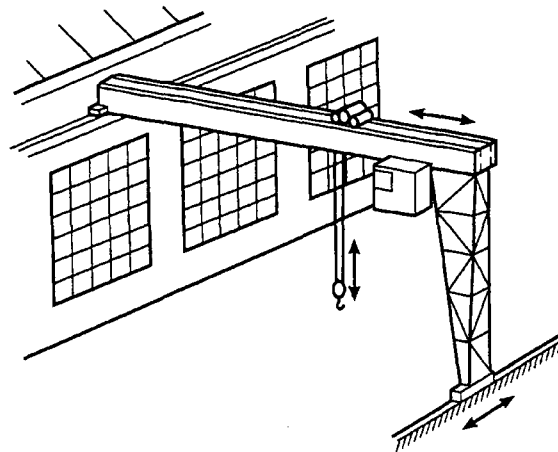

FIG. 4 SEMIGANTRY CRANE

crane, polar: an overhead or gantry crane that travels on a circular runway.

crane, power-operated: a crane whose mechanism is driven by electric, pneumatic, hydraulic, or internal combustion means.

crane, pulpit-operated: a crane whose movements are controlled by an operator through the use of controllers located in a control room or a fixed or movable cab or platform, that is independent of the crane.

crane, remote-operated: a crane whose movements are controlled by an operator through the use of controllers contained in a portable operating station not attached to the crane.

crane, semigantry: a gantry with one end of the bridge rigidly supported on one or more legs that run on a fixed rail or runway, the other end of the bridge being supported by an end truck running on an elevated rail or runway (see Fig. 4).

crane, standby: a crane not in regular service that is used occasionally or intermittently as required.

crane, wall: a crane having a cantilever frame with or without trolley, and supported from a side wall or line of columns of a building. It is a traveling type and operates on a runway attached to the side wall or columns (see Fig. 5).

crane service, heavy: service that involves operating at 85 to 100% of rated load or in excess of 10 lift cycles/hr as a regular specified procedure.

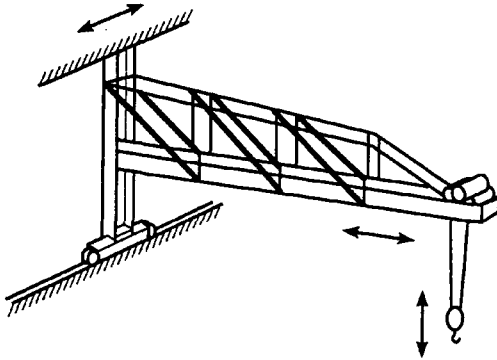

FIG. 5 WALL CRANE

crane service, normal: service that involves operating at less than 85% of rated load and not more than 10 lift cycles/hr except for isolated instances.

crane service, severe: service that involves normal or heavy service with abnormal operating conditions.

designated person: a person selected or assigned by the employer or the employer's representative as being competent to perform specific duties.

drift point: a point on a travel motion master switch or on a manual controller that maintains the brake released while the motor is not energized. This allows for coasting.

drum: the cylindrical member around which the ropes are wound for lifting or lowering the load.

end tie: a structural member that connects the ends of the bridge girders to maintain squareness of the bridge.

equalizer: a device that compensates for unequal length or stretch of a rope.

exposed: applies to hazardous objects not guarded or isolated, and capable of being contacted inadvertently.

gantry leg: the structural member that supports a bridge girder or end tie from the sill.

hazardous (classified) locations: locations where fire or explosion hazards may exist. Locations are classified depending on the properties of the flammable vapors, liquids, or gases, or combustible dusts or fibers that may be present and the likelihood that a flammable or combustible concentration or quantity is present (see National Electrical Code, ANSI/NFPA 70).

class I locations: locations in which flammable gases or vapors are or may be present in the air in

quantities sufficient to produce explosive or ignitable mixtures.

class II locations: locations that are hazardous because of the presence of combustible dust.

class III locations: locations that are hazardous because of the presence of easily ignitable fibers or flyings, but in which such fibers or flyings are not likely to be in suspension in the air in quantities sufficient to produce ignitable mixtures.

hoist: a machinery unit that is used for lifting or lowering a freely suspended (unguided) load.

hoist motion: motion that lifts or lowers a load.

hook, latch-equipped: a type of hook with a mechanical device to close the throat opening of the hook.

lifting devices: devices that are not reeved onto the hoist ropes, such as hook-on buckets, magnets, grabs, and other supplemental devices used for ease of handling certain types of loads. The weight of these devices is to be considered part of the rated load.

limit device: a device that is operated by some part or motion of a power-driven hoist, trolley, or bridge to limit motion.

load: the total superimposed weight on the load block or hook.

load block: the assembly of hook or shackle, swivel, bearing, sheaves, pins, and frame suspended by the hoisting rope or load chain. This shall include any appurtenances reeved in the hoisting ropes.

lockout/tagout: the placement of a lock/tag on the energy-isolating device in accordance with an established procedure.

main hoist: the primary hoist mechanism provided for lifting and lowering the rated load.

man trolley: a trolley having an operator's cab attached to it.

noncoasting mechanical drive: a drive that automatically results in decelerating a trolley or bridge when power is not available.

normal operating conditions (of cab-operated cranes): conditions during which a crane is performing functions within the scope of the original design. Under these conditions, the operator is at the operating control devices, and there is no other person on the crane.

normal operating conditions (of floor-operated cranes): conditions during which a crane is performing

functions within the scope of the original design. Under these conditions, the operator is at the operating control devices that are attached to the crane but operated with the operator off the crane, and there is no person on the crane.

normal operating conditions (of remote-operated cranes): conditions during which a crane is performing functions within the scope of the original design. Under these conditions, the operator is at the operating control devices that are not attached to any part of the crane, and there is no person on the crane.

overload: any load greater than the rated load (see para. 2-3.2.1.1).

parts of line: the number of lines of rope supporting the load block.

pendant station: controls suspended from the crane for operating the unit from the floor.

primary upper-limit device: the first device that, when actuated, limits hoisting motion in the upward direction.

qualified person: a person who, by possession of a recognized degree in an applicable field or a certificate of professional standing, or who by extensive knowledge, training, and experience, has successfully demonstrated the ability to solve or resolve problems relating to the subject matter and work.

rail sweep: a device attached to the crane and located in front of the crane's leading wheels to remove obstructions.

rated load (capacity): the maximum load designated by the manufacturer for which a crane or individual hoist is designed and built.

reeving: a system in which a rope travels around drums or sheaves.

rope: refers to wire rope unless otherwise specified.

runway: an assembly of rails, beams, girders, brackets, and framework on which the crane travels.

service platform: a means provided for workers to perform maintenance, inspections, adjustments, and repairs of cranes.

shall: this word indicates that a rule is mandatory and must be followed.

sheave: a grooved wheel or pulley used with a rope to change direction and point of application of a pulling force.

sheave, nonrunning (equalizer): a sheave used to equalize tension in opposite parts of the rope. Because of its slight movement, it is not termed a running sheave.

sheave, running: a sheave that rotates as the load block is lifted or lowered.

should: this word indicates that a rule is a recommendation, the advisability of which depends on the facts in each situation.

side pull: the portion of the hoist pull acting horizontally when the hoist lines are not operated vertically.

sills: horizontal structural members that connect the lower ends of two or more legs of a gantry crane on one runway.

slash (/): a slash (/) denotes and/or and indicates that two words are to be taken together or individually.

span: the horizontal distance, center to center, between runway rails.

stop: a device to limit travel of a trolley or crane bridge. This device normally is attached to a fixed structure and normally does not have energy-absorbing ability.

switch (valve): a device for making, breaking, or changing the connections in an electric, hydraulic, or pneumatic circuit.

switch, emergency stop: a manually actuated switch to disconnect power independently of the regular operating controls.

switch, limit: a device that is actuated by the motion of a part of a power-driven machine or equipment to alter or disconnect the electric, hydraulic, or pneumatic circuit associated with the machine or equipment.

switch, main (crane disconnect): a switch on the crane controlling the main power supply from the runway conductors.

switch, master: a switch that dominates the operation of contactors, relays, or other remotely operated devices.

switch, master, spring-return: a master switch that, when released, will return automatically to a neutral (off) position.

switch, runway disconnect: a switch, usually at floor level, controlling the main power supply to the runway conductors.

OVERHEAD AND GANTRY CRANES

ASME B30.2-2001

trolley: the unit that travels on the bridge rails and supports the load block.

trolley travel: the trolley movement.

truck: a unit consisting of a frame, wheels, bearings, and axles that supports the bridge girders, the end ties of an overhead crane, or the sill of a gantry crane.

unattended: a condition in which the operator of a crane is not at the operating control devices. However, on a floor-operated crane, if the operating control devices are within sight of the operator and within a distance equal to the span of the crane, the crane should be considered attended.

upper block: a fixed block located on a trolley that, through a system of sheaves, bearings, pins, and frame, supports the load block and its load.

) Section 2-0.3: References

Within the text, references are made to the following publications, copies of which may be obtained from the publishers as indicated.

ASD Manual of Steel Construction, 9th Edition, 1989
LRFD Manual of Steel Construction, 2nd Edition, 2nd Revision, 1998

Publisher: American Institute of Steel Construction (AISC), One East Wacker Drive, Chicago, IL 60601-2001

AISE Technical Report No. 6, June 1996, Specification for Electric Overhead Traveling Cranes for Steel Mill Service

Publisher: Association of Iron and Steel Engineers (AISE), 3 Gateway Center, Pittsburgh, PA 15222

ANSI Z244.1-1982 (R1993), Safety Requirements for the Lock Out/Tag Out of Energy Sources

Publisher: American National Standards Institute (ANSI), 11 West 42nd Street, New York, NY 10036

ANSI A14.3-1992, Safety Requirements for Fixed Ladders¹

ANSI A1264.1-1995, Safety Requirements for Workplace Floor and Wall Openings, Stairs, and Railing Systems¹

Publisher: American Society of Safety Engineers (ASSE), 1800 East Oakton Street, Des Plaines, IL 60018-2187

ANSI Z241.2-1999, Safety Requirements for Melting and Pouring of Metals in the Metalcasting Industry¹
Publisher: American Foundrymen's Society (AFS), 505 State Street, Des Plaines, IL 60016

ANSI Z535.4-1998, Product Safety Signs and Labels¹
Publisher: National Electrical Manufacturers Association (NEMA), 2101 L Street, NW, Suite 300, Washington, DC 20037-1580

ANSI/ASCE 7-95, Minimum Design Loads for Buildings and Other Structures¹

Publisher: American Society of Civil Engineers (ASCE), 1801 Alexander Bell Drive, Reston, VA 20191-4400

ANSI/AWS D1.1-98, Structural Welding Code — Steel¹
ANSI/AWS D14.1-97, Specification for Welding of Industrial and Mill Cranes and Other Material Handling Equipment¹

Publisher: American Welding Society (AWS), 550 NW Le Jeune Road, P.O. Box 351040, Miami, FL 33126

ANSI/NFPA 70-1999, National Electrical Code¹

Publisher: National Fire Protection Association (NFPA), 1 Batterymarch Park, Quincy, MA 02269

ANSI/SAE Z26.1-1996, Safety Glazing Materials for Glazing Motor Vehicles and Motor Vehicles Operating on Land Highways — Safety Standard¹

Publisher: Society of Automotive Engineers (SAE), Inc., 400 Commonwealth Drive, Warrendale, PA 15096

ASME B15.1-1996, Safety Standard for Mechanical Power Transmission Apparatus¹

ASME B30.9-1996, Slings¹

ASME B30.10-1993, Hooks¹

ASME B30.16-1998, Overhead Hoists (Underhung)¹

ASME B30.20-1999, Below-the-Hook Lifting Devices¹

Publisher: The American Society of Mechanical Engineers (ASME), Three Park Avenue, New York, NY 10016-5990; Order Department: 22 Law Drive, Box 2300, Fairfield, NJ 07007-2300

CMAA Specification No. 70-2000, Specifications for Top Running Bridge and Gantry Type Multiple Girder Electric Overhead Traveling Cranes

Publisher: Crane Manufacturers Association of America (CMAA), 8720 Red Oak Boulevard, Suite 201, Charlotte, NC 28217

¹ May also be obtained from American National Standards Institute (ANSI), 11 West 42nd Street, New York, NY 10036.

CHAPTER 2-1 GENERAL CONSTRUCTION AND INSTALLATION

Section 2-1.1: Markings

2-1.1.1 Rated Load Markings — Crane. The rated load of the crane shall be marked on each side of the crane and shall be legible from the ground or floor.

2-1.1.2 Rated Load Markings — Hoist

(a) The rated load of the hoist shall be marked on the hoist or trolley unit or its load block and shall be legible from the ground or floor.

(b) If the crane has more than one hoisting unit, each hoist shall have its rated load marked as per para. 2-1.1.2(a).

2-1.1.3 Manufacturer's Identification Markings. The crane shall be marked with manufacturer's identification information, on a plate or label attached to the crane, as follows:

- (a) name and address of manufacturer
- (b) manufacturer's model or serial number
- (c) voltage of AC or DC power supply and phase and frequency of AC power supply.

2-1.1.4 Multiple Hoist Identification Markings. If the crane has more than one hoisting unit, each hoist shall have an identification marking on the hoist or trolley unit or its load block (i.e., 1 and 2; A and B; north and south; etc.) and shall be legible from the ground or floor. These markings shall also appear on the controllers used by the operator to indicate the controllers that operate each hoist.

2-1.1.5 Warnings

(a) Floor-operated and remote-operated cranes shall have a safety label or labels affixed to the pendant station, portable operating station, or load block. The label or labels shall be in compliance with ANSI Z535.4, and shall include, but not be limited to, cautionary language against:

- (1) lifting more than rated load;
- (2) operating hoist when load is not centered under hoist;
- (3) operating hoist with twisted, kinked, or damaged chain or rope;

- (4) operating damaged or malfunctioning crane;
- (5) lifting people;
- (6) lifting loads over people;
- (7) operating a rope hoist with a rope that is not properly seated in its groove;
- (8) operating manual motions with other than manual power; and
- (9) removing or obscuring safety label.

(b) Cab-operated and pulpit-operated cranes shall have a safety label or labels affixed in the cab or pulpit. The label or labels shall be in compliance with ANSI Z535.4, and shall include, but not be limited to, cautionary language against:

- (1) lifting more than rated load;
- (2) operating hoist when load is not centered under hoist;
- (3) operating hoist with twisted, kinked, or damaged chain or rope;
- (4) operating damaged or malfunctioning crane;
- (5) lifting people;
- (6) lifting loads over people;
- (7) operating a rope hoist with a rope that is not properly seated in its groove; and
- (8) removing or obscuring safety label.

(c) A safety label shall be affixed on all electrical control enclosures. The label shall be in compliance with ANSI Z535.4, and shall include, but not be limited to, information such as:

- (1) Disconnect power and lockout disconnecting means before removing cover or servicing this equipment.
- (2) Do not operate without cover in place.

Section 2-1.2: Clearances

2-1.2.1 Clearance from Obstruction

(a) Clearance shall be maintained between the crane and the building, as well as parallel running cranes and cranes operating at a different elevation, under all normal operating conditions. In the design of new cranes, all factors that influence clearance, such as wheel float, truss sag, bridge skewing, or trolley positions and configurations shall be considered.

(b) Where passageways or walkways are provided on the structure supporting the crane, obstructions shall not be placed so that personnel will be jeopardized by movements of the crane.

2-1.2.2 Clearance Between Parallel Cranes. If the runways of two cranes are parallel, and there are no intervening walls or structures, there shall be clearance provided and maintained between the two bridges.

Section 2-1.3: General Construction — Runways and Supporting Structure

2-1.3.1 Foundations and Anchorages

(a) Permanent concrete or masonry foundations shall rest on footings below the frost line except in permafrost.

(b) Every outdoor crane shall be provided with secure fastenings convenient to apply and to hold the crane against a wind pressure of 30 lb/ft² (1436 Pa). Parking brakes may be considered minimum compliance with this rule.

(c) Where wind forces are specified to be in excess of 30 lb/ft² (1436 Pa), special anchorages, such as latches or tie-downs at the home position, or remotely operated rail clamps for all positions to supplement the primary braking system, shall be provided (ANSI/ASCE 7-88 may be used as a reference for this condition).

(d) Outdoor gantry cranes shall be provided with remotely operated rail clamps or other equivalent devices. Parking brakes may be considered minimum compliance with this rule.

(e) Rail clamps should only be applied when the crane is not in motion.

(f) When rails are used for anchorages, they shall be secured to withstand the resultant forces applied by the rail clamps. If the clamps act on the rail, any projection or obstruction in the clamping area shall be avoided.

(g) A wind-indicating device shall be provided for all outdoor cranes. The device shall be mounted on the crane or the crane runway structure and shall give a visible and audible alarm to the crane operator at a predetermined wind velocity. A single wind-indicating device may serve as an alarm for more than one crane.

2-1.3.2 Crane Runways

(a) Construction of Runways and Rails

(01) (1) The crane runways and supporting structures shall be designed to withstand the loads and forces imposed by the crane. Steel crane runways and support-

ing structures should conform to the design parameters as specified in the applicable AISC Manual of Steel Construction.

(2) Runway columns shall be securely anchored to foundations.

(3) The structure shall be free from detrimental vibration under normal operating conditions.

(4) Rails shall be level, straight, joined, and spaced (01) to the crane span within tolerances as specified in CMAA Specification No. 70, or within tolerances that are compatible with special conditions specified by the crane manufacturer or a qualified person.

(5) Where curves are required, special design will be necessary.

(6) Where grades are required, special design will be necessary.

(b) Runway Stops

(1) Stops shall be provided at the limits of travel of the bridge.

(2) Stops shall engage the bumpers or bumper pads mounted on the bridge.

(3) Stops shall be designed to withstand the forces applied to the bumpers, as specified in para. 2-1.8.2(b).

Section 2-1.4: Crane Construction

2-1.4.1 Welded Construction. All welding procedures and welding operator qualifications to be used on load-sustaining members shall be in accordance with ANSI/AWS D1.1, except as modified by ANSI/AWS D14.1. Where special steels or other materials are used, the manufacturer or qualified person shall provide welding procedures.

2-1.4.2 Girders. All cranes built after the effective (01) date of this volume should conform to the design parameters as specified, and applicable, in CMAA Specification No. 70 or AISE Technical Report No. 6.

2-1.4.3 Modifications. Cranes may be modified or (01) rerated provided such modifications and the supporting structure are analyzed thoroughly and approved by a qualified person or manufacturer of cranes. A rerated crane or one whose load-supporting components have been modified shall be tested in accordance with para. 2-2.2.2. The new rated load shall be displayed in accordance with paras. 2-1.1.1 and 2-1.1.2.

Section 2-1.5: Cabs — Normal or Skeleton (if Provided)

2-1.5.1 Cab Location

(a) The general arrangement of the cab and the

location of the control and protective equipment should be such that all operating handles are within reach of the operator when facing the area to be served by the load block, or while facing the direction of travel of the cab.

(b) The arrangement of the cab should allow the operator a full view of the load block in all positions. This is an important and desirable condition, but it is recognized that there are physical arrangements that may make this impossible, and, when the load block is in these positions, the operator shall be aided by other means such as, but not limited to, closed-circuit TV, mirrors, radio, telephone, or a signalperson.

(c) The cab shall be clear of all fixed structures within the area of possible movement.

(d) The clearance of the cab above the working floor or passageway should be not less than 7 ft (2.1 m), except when operations require dimensions that are less. In this case, precautions shall be taken during the operation of the crane to keep personnel and other obstructions clear of the low overhead.

2-1.5.2 Cab Construction

(a) The cab shall be constructed and attached to the crane to minimize swaying or vibrations.

(b) If an integral outside platform is provided, the door (if provided) shall be a sliding type or shall open outward.

(c) In the absence of an outside platform, the door (if provided) shall open inward or slide and shall be self-closing. It shall be equipped with positive latching devices to prevent inadvertent opening.

(d) The width of a doorway shall have a clear opening of not less than 18 in. (460 mm).

(e) A trapdoor (if provided) above the cab or in the cab roof, shall have a clear opening of not less than 24 in. (610 mm) on each side. There should be no obstructions in the opening path of the trap door that prevents opening of the trap door for the purpose for which it is designed.

(f) Guard railings and toeboards shall be in compliance with ANSI A1264.1.

(g) Outdoor cabs should be enclosed. All cab glazing shall be safety-glazing material, as defined in ANSI/SAE Z26.1.

(h) The cab construction shall offer protection from falling objects, if this possibility exists. The protection shall support 50 lb/ft² (2400 Pa) static load.

(i) If the cab of a molten material crane is exposed to heat, it shall be provided with the following, or equivalent, protection:

- (1) cab enclosed as for outdoor protection;
- (2) windows with metal sash and heat-resisting, safety-glazing material, as defined in ANSI/SAE Z26.1;
- (3) floor insulated with heat-resistant material;
- (4) a shield of metal at least $\frac{1}{8}$ in. (3 mm) thick located at least 6 in. (152 mm) below bottom of cab floor; and
- (5) materials that will not propagate combustion or rekindle.

2-1.5.3 Access to Crane. Access to the cab or bridge walkway shall be by a fixed ladder, stairs, or platform. The ladder shall be in conformance with ANSI A14.3, except as modified to meet the requirements of this volume.

2-1.5.4 Toolbox. If a receptacle is provided for the stowing of tools and oil cans, it shall be made of a noncombustible material and shall be securely fastened in the cab or on the service platform.

2-1.5.5 Fire Extinguisher. A portable fire extinguisher, with a basic minimum extinguisher rating of 10 BC, shall be installed in the cab.

2-1.5.6 Lighting. Cab lighting, either natural or artificial, shall provide a level of illumination that enables the operator to observe the operating controls.

Section 2-1.6: Lubrication

2-1.6.1 Lubricating Point. If lubrication is required, accessible means for lubrication should be provided.

Section 2-1.7: Service Platforms (Footwalks)

2-1.7.1 Construction of Service Platforms. Service platforms, when provided with or added to the crane, and attached to the crane, shall conform to the following requirements:

(a) The dimension of the working space in the vertical direction from the floor surface of the platform to the nearest overhead obstruction shall be a minimum of 48 in. (1220 mm) at the location where a person is performing a function while on the platform.

(b) Crane travel shall be prohibited or restricted while a person is on a service platform and the overhead platform clearance is less than 78 in. (1980 mm) at any location in the path of travel of the crane.

(c) Service platforms shall have a clear passageway at least 18 in. (457 mm) wide, except at the bridge

drive mechanism where not less than 15 in. (380 mm) of clear passageway shall be allowed.

(d) The dimension of the working space in the direction of access to live (energized) electrical parts which are likely to require examination, adjustment, servicing, or maintenance while energized shall be a minimum of 30 in. (762 mm).¹

(e) The door(s) of electrical control cabinets shall either open at least 90 deg or be removable.¹

(f) Service platforms shall be designed to sustain a distributed load of at least 50 lb/ft² (2400 Pa).

(g) Service platforms shall have a slip-resistant walking surface.

(h) Service platforms shall be provided with guard railings and toeboards.

(1) Guard railings and toeboards shall be in compliance with ANSI A1264.1.

(2) Guard railings shall be at least 42 in. (1065 mm) high and shall be provided with an intermediate railing.

2-1.7.2 Ladders and Stairways

(a) Gantry cranes shall be provided with ladders or stairways extending from the runway elevation to the footwalk or cab platform.

(b) Stairways shall be equipped with metal handrails and should be at an angle of not more than 50 deg with the horizontal. Walking surfaces shall be of a slip-resistant type.

(c) Ladders shall be fastened in place and shall be constructed in compliance with ANSI A14.3, except as modified to meet the requirements of this volume.

2-1.7.3 Egress. There should be a means of egress from cab-operated cranes to permit departure under emergency conditions. The means of egress should depend on the facts of the situation.

Section 2-1.8: Stops and Bumpers

2-1.8.1 Trolley Stops

(a) Stops shall be provided at the limits of travel of the trolley.

(b) Stops shall engage the bumpers or bumper pads mounted on the trolley, as specified in para. 2-1.8.3.

(c) Stops shall be designed to withstand the forces applied by the bumpers, as specified in para. 2-1.8.3.

2-1.8.2 Bridge Bumpers

(a) A power-operated bridge shall be provided with

bumpers or other automatic means providing equivalent effect.

(b) Bridge bumpers shall have the following minimum characteristics:

(1) energy-absorbing (or -dissipating) capacity to stop the bridge when traveling with power off in either direction at a speed of at least 40% of rated load speed;

(2) the capability of stopping the bridge (but not the load block or lifted load unless they are guided vertically) at a rate of deceleration not to exceed an average of 3 ft/sec² (0.9 m/s²) when traveling with power off in either direction at 20% of rated load speed; and

(3) be designed and installed with a means of retaining the bumper in case of broken or loosened mounting connections.

(c) Multiple power-operated bridges operating on the same runway shall have contact bumpers that meet the requirements of (b)(2) above.

2-1.8.3 Trolley Bumpers

(a) A power-operated trolley shall be provided with bumpers or other automatic means providing equivalent effect.

(b) Trolley bumpers shall have the following minimum characteristics:

(1) energy-absorbing (or -dissipating) capacity to stop the trolley when traveling with power off in either direction at a speed of at least 50% of rated load speed;

(2) the capability of stopping the trolley (but not the load block or lifted load unless they are guided vertically) at a rate of deceleration not to exceed an average of 4.7 ft/sec² (1.4 m/s²) when traveling with power off in either direction at one-third of rated load speed; and

(3) be designed and installed with a means of retaining the bumper in case of broken or loosened mounting connections.

(c) Multiple power-operated trolleys operating on the same bridge shall have contact bumpers that meet the requirements of (b)(2) above.

Section 2-1.9: Rail Sweeps

2-1.9.1 Bridge Rail Sweeps

(a) Bridge truck rail sweeps shall be provided in front of the leading wheels on both ends of the bridge end truck.

(b) The rail sweep shall clear the rail of objects on the runway which, if they came into contact between

¹ Source: ANSI/NFPA No. 70, National Electrical Code.

the wheel and rail, could cause damage to the wheel or derail the wheel.

(1) Clearance between the top surface of the rail head and the bottom of the sweep should not exceed $\frac{3}{16}$ in. (5 mm).

(2) On overhead crane end trucks, the sweep shall extend below the top surface of the rail head, for a distance not less than 50% of the thickness of the rail head, on both sides of the rail head.

(3) On gantry crane end trucks, when the rail head is located above the pavement or ground level, the sweep shall extend below the top surface of the rail head, for a distance not less than 50% of the thickness of the rail head, on both sides of the rail head.

(4) Clearance between the vertical inside surfaces of the sweep should be equal to the wheel tread width plus $\frac{3}{8}$ in. (10 mm), and clearance should be evenly spaced on each side of the wheel tread width.

2-1.9.2 Trolley Rail Sweeps

(a) Trolley truck rail sweeps should be provided in front of the leading wheels on both ends of the trolley end truck.

(b) The rail sweep shall clear the rail of objects on the bridge which, if they came into contact between the wheel and rail, could cause damage to the wheel or derail the wheel.

(1) Clearance between the top surface of the rail head and the bottom of the sweep should not exceed $\frac{3}{16}$ in. (5 mm).

(2) The sweep shall extend below the top surface of the rail head, for a distance not less than 50% of the thickness of the rail head, on both sides of the rail head.

(3) Clearance between the side surface of the rail head and the side of the sweep which extends below the top surface of the rail head should be equal to crane float plus $\frac{3}{16}$ in. (5 mm).

Section 2-1.10: Guards for Moving Parts

(a) Exposed moving parts, such as gears, set screws, projecting keys, and drive chain and sprockets, which constitute a hazard under normal operating conditions, shall be guarded.

(b) Each guard shall be capable of supporting, without permanent deformation, the weight of a 200-lb (90-kg) person, unless the guard is located where it is not probable that a person will step on it (see ASME B15.1).

Section 2-1.11: Truck Frame Drop

Means shall be provided to limit the drop of bridge and trolley truck frames to 1 in. (25 mm) in case of wheel, axle, or bearing breakage.

Section 2-1.12: Brakes and Braking Means

2-1.12.1 Hoist Holding Brakes

(a) Each hoisting unit of the crane shall be equipped with at least one holding brake. The holding brake shall be applied to the motor shaft or a gear reducer shaft and shall have a torque rating not less than the percentage of rated load hoisting torque at the point where the brake is applied as follows:

(1) 125% of rated load hoisting torque when used with a control braking means other than mechanical,

(2) 100% of rated load hoisting torque when used with a mechanical control braking means, and

(3) 100% of rated load hoisting torque for each brake if two holding brakes are provided.

(b) Each hoisting unit of a crane that handles molten material shall be equipped with one of the following arrangements.

(1) Two holding brakes shall be provided, one of which is applied to a gear reducer shaft, plus control braking means. Each holding brake shall have a torque rating not less than 100% of rated load hoisting torque at the point where the brake is applied.

(2) One holding brake shall be provided if the hoisting unit has a mechanical load brake or a control braking means that provides controlled lowering of the load upon loss of power. The holding brake shall have a torque rating not less than 150% of rated load hoisting torque at the point where the brake is applied.

(c) Each hoist holding brake shall have thermal capacity for the frequency of operation required by the service.

(d) Hoist holding brakes shall be applied automatically when power to the brake is removed.

(e) Hoist holding brakes shall be provided with means to adjust for lining wear.

2-1.12.2 Hoist Control Braking Means

(a) Each hoisting unit of the crane shall be equipped with a control braking means that will control the load during lowering to a maximum speed of 120% of rated lowering speed for the load being handled.

(b) Hoist control braking means can be electrical, such as regenerative, dynamic, countertorque, or eddy-current; mechanical; hydraulic; or a worm-gear hoist

where the angle of the worm is such as to prevent the load from accelerating in the lowering direction.

(c) Hoist control braking means shall have thermal capacity for the frequency of operation required by the service.

2-1.12.3 Trolley Brakes and Braking Means

(a) Each power-driven trolley unit of the crane shall be equipped with either a braking means or have trolley drive frictional characteristics that will provide stopping and holding functions, under conditions where the rails are dry and free of snow and ice, as follows:

(1) Have torque capability to stop trolley travel within a distance in feet (meters) equal to 10% of rated load speed in ft/min (m/min) when traveling with rated load.

(2) Have torque capability to impede horizontal motion of the trolley against a horizontal force equal to 1% of the combined weight of the trolley, hoist, and rated load when the trolley is in a parked condition.

(b) A power-driven, cab-operated crane with the cab on the trolley shall be equipped with a trolley brake that will provide the stopping and holding functions described in paras. 2-1.12.3(a)(1) and (2).

(c) Each trolley brake shall have thermal capacity for the frequency of operation required by the service.

2-1.12.4 Bridge Brakes and Braking Means

(a) A power-driven bridge shall be equipped with either a braking means or have bridge drive frictional characteristics that will provide stopping and holding functions, under conditions where the rails are dry and free of snow and ice, as follows:

(1) Have torque capability to stop bridge travel within a distance in feet (meters) equal to 10% of rated load speed in ft/min (m/min) when traveling with rated load.

(2) Have torque capability to impede horizontal motion of the bridge against a horizontal force equal to 1% of the combined weight of the bridge, trolley, hoist, and rated load when the bridge is in a parked condition.

(b) A power-driven, cab-operated crane shall be equipped with a bridge brake that will provide the stopping and holding functions described in paras. 2-1.12.4(a)(1) and (2).

(c) Each bridge brake shall have thermal capacity for the frequency of operation required by the service.

(01) 2-1.12.5 Trolley and Bridge Brake Provisions.

General provisions as outlined below apply to, as merited, trolley and bridge brakes.

(g) Brakes may be applied by mechanical, electrical, pneumatic, hydraulic, or gravitational means.

(b) Brakes shall be provided with means of adjustment to compensate for lining wear.

(c) Brake pedals, latches, and levers should allow release without the exertion of greater force than was used in applying the brake.

(d) Foot-operated brakes shall require an applied force of not more than 70 lb (310 N) to develop rated brake torque.

(e) Foot-operated brake pedals shall be so constructed that the operator's foot will not readily slip off the pedal.

(f) Foot-operated brake pedals should be so located that they are convenient to the operator at the controls.

(g) Foot-operated brakes shall be equipped with a means for positive release when force is released from the pedal.

(h) When provided, a parking brake shall:

(1) be applied automatically or manually;

(2) impede horizontal motion of the trolley or bridge in accordance with the requirements of paras. 2-1.12.3(a)(2) or 2-1.12.4(a)(2); and

(3) not prohibit the use of a drift point in the control circuit.

(i) When provided, a service brake shall:

(1) be applied manually by the operator during normal operation; and

(2) stop trolley or bridge travel in accordance with the requirements of paras. 2-1.12.3(a)(1) or 2-1.12.4(a)(1).

(j) When provided, a drag brake shall provide a continuous retarding torque without external control.

(k) When provided an emergency brake shall:

(1) be applied when initiated by the operator, or automatically upon loss of power;

(2) stop trolley or bridge travel in accordance with the requirements of paras. 2-1.12.3(a)(1) or 2-1.12.4(a)(1); and

(3) impede horizontal motion of the trolley or bridge in accordance with the requirements of paras. 2-1.12.3(a)(2) or 2-1.12.4(a)(2).

Section 2-1.13: Electrical Equipment

2-1.13.1 General

(a) Wiring and equipment shall comply with Article 610 of ANSI/NFPA No. 70, National Electrical Code.

(b) The control circuit voltage shall not exceed 600V for AC or DC.

(c) The control circuit voltage in pendant push buttons shall not exceed 150V for AC or 300V for DC.

(d) Where multiple conductor cable is used with a suspended push-button station, the station shall be supported so that the electrical conductors are protected from strain.

(e) Pendant control stations shall be constructed to prevent electrical shock. The push-button enclosure shall be at ground potential and marked for identification of functions.

2-1.13.2 Equipment

(a) Electrical equipment shall be located or enclosed so that, under normal operating conditions, energized parts will not be exposed to inadvertent contact.

(b) Energized parts of electrical equipment shall be protected from direct exposure to grease, oil, and moisture, and they should be protected from dirt.

(c) If guards are provided for energized parts, the guards shall be constructed or located so that they cannot be deformed, under normal operating conditions, to make inadvertent contact with energized parts.

2-1.13.3 Controllers

(a) Cranes not equipped with spring-return controllers, spring-return master switches, or momentary contact push buttons, shall be provided with a device that will disconnect all motors from the line in the event of a power failure. This disconnect device shall not permit any motor to be restarted until the controller or master switch handle is brought to the off position, or a reset switch or power-on button is operated.

(b) For cab- or pulpit-operated cranes, lever-operated manual controllers and master switches shall be provided with a spring-return arrangement, off-point detent, or off-point latch.

(c) For cab- or pulpit-operated cranes, the manual controller or master switch operating handle shall be located within reach of the operator.

(d) For cab- or pulpit-operated cranes, the movement of each operating handle should be in the same general direction as the resultant movement of the load, except as shown in Figs. 6 and 7.

(e) For cab- or pulpit-operated cranes, the arrangement of manual controllers or master switches should conform to Figs. 6 and 7.

(f) If a magnet controller is provided, the on (lift) direction shall be toward the operator and the off (drop) direction away from the operator.

(g) For floor-operated cranes, the controller or controllers, if rope operated, shall automatically return to the off position when released by the operator.

(h) Push buttons in pendant stations shall return to the off position when pressure is released by the crane operator.

(i) Automatic cranes shall be so designed that operation of all motions shall be discontinued if the automatic sequence control becomes ineffective. The completion of the last command is permissible if power is available.

(j) Remote-operated cranes shall function so that if the control signal for any crane motion becomes ineffective, that crane motion shall stop, and, conversely, signals received from any source other than the operating station (transmitter) shall not result in operation of any motion of the crane.

(k) The arrangement of pendant push-button stations and radio-control transmitters should conform to Figs. 8 and 9, respectively. Compass directions may be substituted for "right-left" and "forward-reverse" in Fig. 8, and for W, X, Y, and Z in Fig. 9.

(l) Master switches shall be labeled to indicate their functions.

2-1.13.4 Resistors

(a) Resistor units shall be supported to minimize vibration effect.

(b) Provisions shall be made to prevent broken parts or molten metal from falling on the operator or from the crane.

(c) If resistor enclosures are provided, the enclosures shall be installed so that the accumulation of combustible matter is minimized.

2-1.13.5 Switches

(a) The power supply to the runway conductors shall be controlled by a switch or circuit breaker located on a fixed structure, accessible from the floor, and arranged to be locked in the open position.

(b) On cab-operated cranes, a switch or circuit breaker of the enclosed type with provision for locking in the open position shall be provided in the leads from the runway conductors. A means of opening this device shall be located within the reach of the operator when the operator is in the operating position. When the operator opens this switch or circuit breaker, the holding brake(s) should set.

(c) On floor-, remote-, or pulpit-operated cranes, a device of the enclosed type shall be provided in the leads from the runway conductors. This device shall be mounted on the bridge or footwalk near the runway collectors. There shall be provisions for locking the device in the open position unless the crane is the only load on a lockable switch or circuit breaker that is accessible from the floor. One of the following types

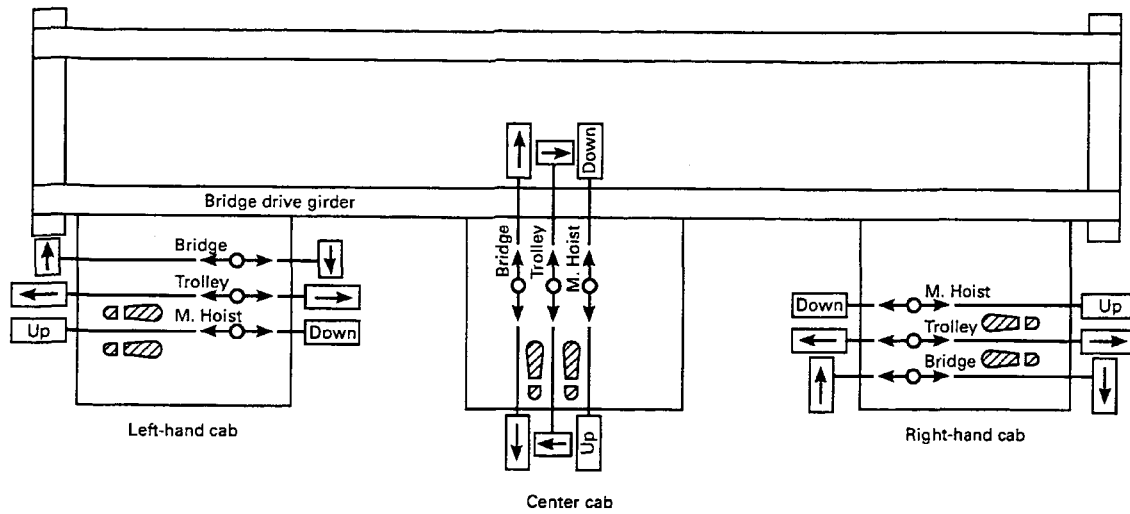

FIG. 6 RECOMMENDED ARRANGEMENT OF CONTROLLERS OR MASTER SWITCHES (THREE-MOTOR CRANE)

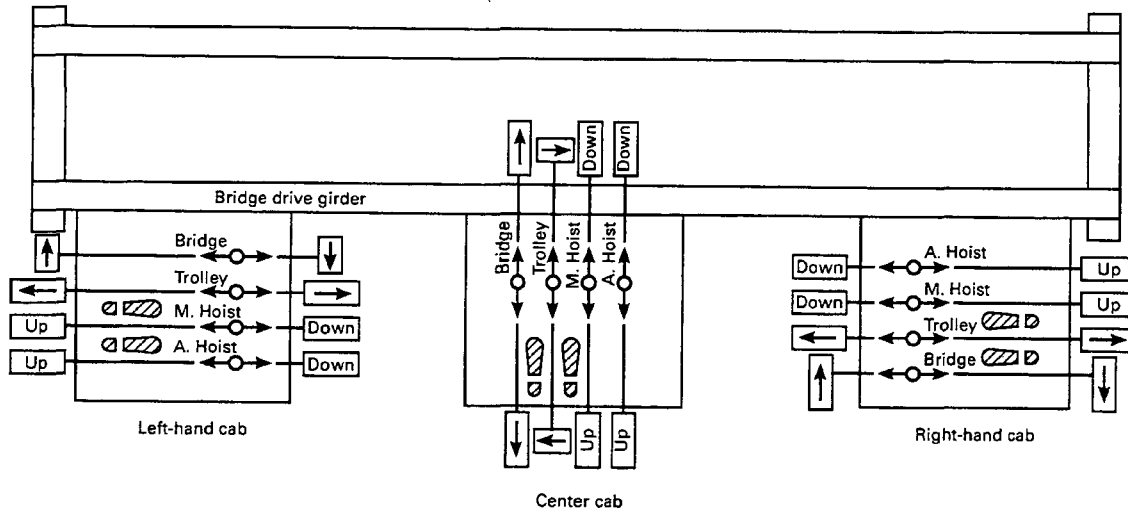

FIG. 7 RECOMMENDED ARRANGEMENT OF CONTROLLERS OR MASTER SWITCHES (FOUR-MOTOR CRANE)

of floor-, remote-, and pulpit-operated disconnects shall be provided:

(1) nonconductive rope attached to the main disconnect device on a floor-operated crane. If this is selected, the rope shall be suspended adjacent to the operating ropes if manual controllers are used, or near the pendant push-button station if magnetic controls are used.

(2) an under-voltage trip for a main circuit breaker,

operated by an emergency stop button in the pendant push-button station or the pulpit.

(3) a main line contactor operated by a switch or push button on the pendant push-button station, the remote control station, or the pulpit.

(d) Power-driven hoists shall be designed and constructed so that the load block, either loaded or empty, shall not exceed the upper limit of travel. On wire-rope hoists, if a geared or other limit switch or device

ASME B30.2-2001

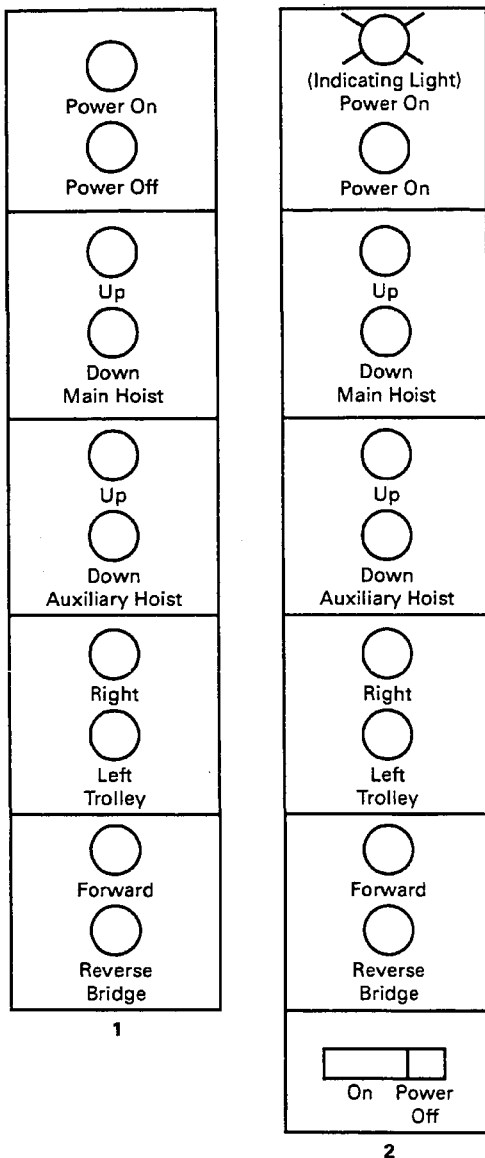

GENERAL NOTE: In each user location, the relative arrangement of units on crane pendant push-button stations should be standardized. In the absence of such standardization, suggested arrangements are shown in arrangements 1 and 2.

FIG. 8 RECOMMENDED ARRANGEMENT OF CONTROLLERS (PENDANT PUSH-BUTTON STATION ARRANGEMENT)

OVERHEAD AND GANTRY CRANES

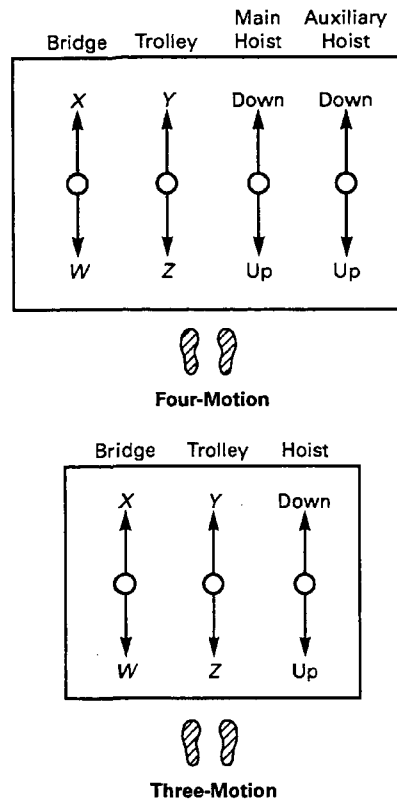

GENERAL NOTE: Markings on the crane, visible from the floor, shall indicate the direction of bridge and trolley travel corresponding to the W, X, Y, and Z designations on the transmitter. The letters used are only intended for the purpose of illustration.

Designations should be selected as appropriate to each illustration.

FIG. 9 RECOMMENDED ARRANGEMENT OF CONTROLLERS (RADIO CRANE CONTROL TRANSMITTER LEVER ARRANGEMENT)

that operates in relation to drum turns is used, an additional limit switch or device that operates independent of drum rotations shall be provided.

(e) Lower-travel-limit devices should be provided for power-driven hoists used in applications where the load block enters pits or hatchways in the floor.

2-1.13.6 Runway Conductors. Conductors of the open type, mounted on the crane runway beams or overhead, shall be so located or guarded that persons cannot inadvertently come into contact with the energized conductors under normal operating conditions or under maintenance procedures as stated in para. 2-2.3.2.

2-1.13.7 Lifting Magnets

(a) A crane for use with a lifting magnet shall have a separate magnet circuit switch of the enclosed type with provision for locking in the open (off) position. The magnet disconnect switch shall be connected on the line side (power supply side) of the crane disconnect switch.

(b) Means shall be provided for discharging the inductive load of a lifting magnet.

(c) Indication or signal lights should be provided to indicate that power to a lifting magnet is on or off. These lights, if used, shall be visible to the crane operator and to persons on the floor.

(d) For a remote-operated crane, the loss of the remote signal shall not result in demagnetizing the lifting magnet.

2-1.13.8 Extension Lamps. If a service receptacle is provided in the cab or on the bridge, it shall be a grounded-type permanent receptacle not exceeding 300V.

Section 2-1.14: Hoisting Equipment**2-1.14.1 Sheaves**

(a) Sheave grooves shall be free from surface defects which could cause rope damage. The cross-sectional radius at the bottom of the groove should be such as to form a close-fitting saddle for the size of rope used. The sides of the groove shall be tapered outward and rounded at the rim to facilitate entrance of the rope into the groove. Flange rims shall run true about the axis of rotation.

(b) Sheaves carrying ropes, which can be momentarily unloaded, shall be provided with close-fitting guards, or other devices, to guide the rope back into the groove when the load is reapplied.

(c) The sheaves in the bottom block shall be equipped with close-fitting guards that will minimize the possibility of ropes becoming fouled when the block is lying on the ground with the ropes loose.

(d) All running sheaves shall be equipped with means for lubrication. Permanently lubricated, sealed, or shielded bearings shall be acceptable.

2-1.14.2 Drums. Rope drums shall be grooved, except when the crane is provided by the manufacturer for a special application. This requirement does not preclude the use of multiple layer spooling. The grooves shall be free from surface defects that could cause rope damage. The cross-sectional radius at the bottom of

the groove should be such as to form a close-fitting saddle for the size of rope used.

2-1.14.3 Ropes

(a) The hoisting ropes shall be of a recommended construction for crane service. The total load (rated load plus weight of load block) divided by the number of parts of line shall not exceed 20% of the minimum breaking strength of the rope.

(b) Socketing shall be done in a manner recommended by the rope or fitting manufacturer or a qualified person.

(c) Rope shall be secured to the drum as follows:

(1) No less than two wraps of rope shall remain on the drum at each anchorage of the hoisting drum when the hook is in its extreme low position unless a lower-limit device is provided, in which case no less than one wrap shall remain.

(2) The rope end shall be anchored by a clamp attached to the drum, or by a socket arrangement specified by the crane or rope manufacturer. The rope clamps shall be tightened evenly to the manufacturer's recommended torque.

(d) Eye splices shall be made in recommended manner. Rope thimbles should be used in the eye.

(e) Wire rope clips shall be drop-forged steel of the single-saddle (U-bolt) or double-saddle type. Malleable cast iron clips shall not be used. For spacing, number of clips, and torque values, refer to the clip manufacturer's recommendation. Wire rope clips attached with U-bolts shall have the U-bolt over the dead end of the rope and live rope resting in the clip saddle. Clips shall be tightened evenly to the recommended torque. After the initial load is applied to the rope, the clip nuts shall be retightened to the recommended torque to compensate for any decrease in rope diameter caused by the load. Rope clip nuts should be retightened periodically to compensate for any further decrease in rope diameter during usage.

(f) Swaged or compressed fittings shall be applied as recommended by the rope, crane, or fitting manufacturer or qualified person.

(g) Wherever exposed to ambient temperatures at the rope in excess of 180°F (82°C), rope having an independent wire-rope or wire-strand core, or other temperature-damage-resistant core, shall be used.

(h) Replacement rope shall be the same size, grade, and construction as the original rope furnished by the crane manufacturer, unless otherwise recommended by a rope or crane manufacturer or qualified person due to actual working condition requirements.

NOTE: *minimum breaking strength* formerly referred to as *nominal breaking strength*.

2-1.14.4 Equalizers. If a load is supported by more than one part of rope, the tension in the parts shall be equalized.

2-1.14.5 Hooks. Hooks shall meet the manufacturer's recommendations and shall not be overloaded. If hooks are of the swiveling type, they should rotate freely. Latch-equipped hooks shall be used unless the application makes the use of the latch impractical or unnecessary. When required, a latch or mousing shall be provided to bridge the throat opening of the hook for the purpose of retaining slings, chains, or other similar parts, under slack conditions (see ASME B30.10).

2-1.14.6 Guards for Hoisting Ropes

(a) If it is possible for hoisting ropes to foul or chafe on adjacent parts of the crane under normal operating conditions, guards shall be installed to minimize damage to the rope.

(b) A guard shall be provided to prevent contact between bridge or runway conductors and hoisting ropes if, under normal operating conditions, they can come into contact.

Section 2-1.15: Warning Devices or Means for a Crane With a Power-Traveling Mechanism

2-1.15.1 Cab- and Remote-Operated Cranes

(a) A warning device shall be provided.

(b) Refer to para. 2-3.1.7(e) for operation of the device.

2-1.15.2 Floor-Operated Cranes

(a) A warning device should be provided for installations where the ability of the operator to warn persons in the path of the load is impaired.

(b) Refer to para. 2-3.1.7(e) for operation of the device.

2-1.15.3 Types of Devices. One or more of the following devices shall be provided when required:

- (a) manually operated gong
- (b) power-operated bell, siren, or horn
- (c) rotating beacon
- (d) strobe light

Section 2-1.16: Manual

2-1.16.1 The crane manufacturer shall furnish with each crane at least one copy of the manual. The manual shall include general information applicable to the following:

- (a) installation
- (b) operation
- (c) inspection
- (d) testing
- (e) lubrication
- (f) maintenance
- (g) parts
- (h) wiring diagram (may be supplied separately)

2-1.16.2 Personnel responsible for the supervision, installation, operation, inspection, or maintenance of the crane shall be familiar with the applicable contents of the manual furnished with the crane.

CHAPTER 2-2

INSPECTION, TESTING, AND MAINTENANCE

Section 2-2.1: Inspection

2-2.1.1 Inspection Classification

(a) *Initial Inspection.* New, reinstalled, altered, repaired, and modified cranes shall be inspected by a designated person prior to initial use to verify compliance with applicable provisions of this volume. Inspection of altered, repaired, and modified cranes may be limited to the provisions affected by the alteration, repair, or modification, as determined by a qualified person.

(b) Inspection procedure for cranes in regular service is divided into two general classifications based upon the intervals at which inspection should be performed. The intervals in turn are dependent upon the nature of the critical components of the crane and the degree of their exposure to wear, deterioration, or malfunction. The two general classifications are designated as *frequent* and *periodic*, with respective intervals between inspection as defined below.

(1) *Frequent Inspection.* Visual examinations by the operator or other designated personnel with records not required, as follows:

- (a) normal service — monthly
- (b) heavy service — weekly to monthly
- (c) severe service — daily to weekly

(2) *Periodic Inspection.* Visual inspection of the equipment in place by a designated person making records of apparent external conditions to provide the basis for a continuing evaluation, as follows:

- (a) normal service — yearly
- (b) heavy service — yearly
- (c) severe service — quarterly

2-2.1.2 Frequent Inspection

(a) Frequent inspection shall include observations during operation.

(b) A designated person shall determine whether conditions found during the inspection constitute a hazard and whether a more detailed inspection is required.

(c) The following items shall be inspected:

- (1) operating mechanisms for proper operation, proper adjustment, and unusual sounds;
- (2) upper-limit device(s) in accordance with para. 2-3.2.4(a);
- (3) tanks, valves, pumps, lines, and other parts of air or hydraulic systems for leakage;
- (4) hooks and hook latches (if used) in accordance with ASME B30.10;
- (5) hoist ropes and end connections in accordance with para. 2-2.4.1(a); and
- (6) rope of proper spooling onto the drum(s) and sheave(s).

2-2.1.3 Periodic Inspection

(a) A designated person shall determine whether conditions found during inspection constitute a hazard and whether disassembly is required for additional inspection.

(b) The inspection shall include the items listed in para. 2-2.1.2(c) and the following items, as applicable:

- (1) deformed, cracked, or corroded members;
- (2) loose or missing bolts, nuts, pins, or rivets;
- (3) cracked or worn sheaves and drums;
- (4) worn, cracked, or distorted parts such as pins, bearings, wheels, shafts, gears, rollers, locking and clamping devices, bumpers, and stops;
- (5) excessive wear of brake system parts;
- (6) excessive wear of drive chain sprockets and excessive drive chain stretch;
- (7) deterioration of controllers, master switches, contacts, limit switches, and push-button stations, but not limited to these items;
- (8) wind indicators for proper operation;
- (9) gasoline, diesel, electric, or other power plants for proper operation;
- (10) motion-limit devices that interrupt power or cause a warning to be activated for proper performance. Each motion shall be inched or operated at low speed into the limit device with no load on the crane;
- (11) rope reeving for compliance with crane manufacturer's design; and

(12) all function, instruction, caution, and warning labels or plates for legibility and replacement.

2-2.1.4 Cranes Not in Regular Service

(a) A crane that is used in infrequent service, which has been idle for a period of 1 month or more, but less than 1 year, shall be inspected before being placed in service in accordance with the requirements listed in para. 2-2.1.2.

(b) A crane that is used in infrequent service, which has been idle for a period of 1 year or more, shall be inspected before being placed in service in accordance with the requirements listed in para. 2-2.1.3.

2-2.1.5 Inspection Records. Dated inspection reports of comparable records shall be made on critical items such as hoisting machinery, sheaves, hooks, chains, ropes, and other lifting devices as listed in para. 2-2.1.3. Records shall be placed on file.

Section 2-2.2: Testing

2-2.2.1 Operational Tests

(a) New, reinstalled, altered, repaired, and modified cranes shall be tested by a designated person prior to initial use to ensure compliance with this volume.

(b) Tests shall include, as applicable, the following functions:

- (1) lifting and lowering;
- (2) trolley travel;
- (3) bridge travel;
- (4) hoist-limit devices;

(a) the trip setting of hoist-limit devices shall be determined by tests with an empty hook comprising a series of runs, each at increasing hook speed up to the maximum speed, unless the hoist has only a single speed;

(b) the actuating mechanism of the upper-limit device shall be located or adjusted so that it will trip the device in sufficient time to prevent contact of the load block or load with any part of the trolley or bridge;

- (5) travel-limiting devices; and
- (6) locking and indicating devices, if provided.

(c) Operational testing of altered, repaired, and modified cranes may be limited to the functions affected by the alteration, repair, or modification, as determined by a qualified person.

2-2.2.2 Load Test

(a) New, reinstalled, altered, repaired, and modified cranes should be load tested prior to initial use, as determined by a qualified person.

(b) Load testing of altered, repaired, and modified cranes may be limited to the functions affected by the alteration, repair, or modification, as determined by a qualified person.

(c) The replacement of load chain and rope is specifically excluded from this load test; however, an operational test of the hoist shall be made in accordance with para. 2-2.2.1(b) prior to putting the crane back in service.

(d) If a load test is conducted, the load shall be not less than 100% of the rated load of the crane or hoist(s), whichever governs; or more than 125% of the rated load of the crane or hoist(s), whichever governs; unless otherwise recommended by the manufacturer or a qualified person.

(e) If a load test is conducted, the person conducting the load test shall prepare a written report of the load sustained during the test and the operations performed during the test. Reports shall be placed on file.

(f) If a load test is conducted, operations shall be performed as outlined below or as modified by a qualified person.

(1) Hoist the test load a distance to assure that the load is supported by the crane and held by the hoist brake(s).

(2) Transport the test load by means of the trolley for the full length of the bridge.

(3) Transport the test load by means of the bridge for the full length of the runway in one direction with the trolley as close to the extreme right-hand end of the crane as practical, and in the other direction with the trolley as close to the left-hand end of the crane as practical.

(4) Lower the test load, and stop and hold the test load with the brake(s).

Section 2-2.3: Maintenance

2-2.3.1 Preventive Maintenance

(a) A preventive maintenance program should be established. The program should be based on the recommendations outlined in the crane manufacturer's manual and, when appropriate, additional recommendations outlined by a qualified person based upon review of the crane application and operation. Dated records should be placed on file.

(b) Replacement parts shall be at least equal to the original manufacturer's specifications.

2-2.3.2 Maintenance Procedure

(a) The following precautions shall be taken before performing maintenance on a crane:

(1) The crane shall be moved to a location where it will cause the least interference with other cranes and operations in the area.

(2) If a load is attached to the crane, it shall be landed.

(3) All controllers shall be placed in the off position.

(4) A lockout/tagout procedure shall be performed (see para. 2-3.5.1).

(5) Warning signs and barriers shall be utilized on the floor beneath the crane where overhead maintenance work creates a hazard.

(6) If the runway remains energized, stops or a signalperson(s), located full-time at a visual vantage point for observing the approach of an active crane(s), shall be provided to prohibit contact by the active crane(s) with the idle crane, with persons performing maintenance, and with equipment used in performing the maintenance.

(7) A guard or barrier shall be installed between adjacent runways for the length of any established work area to prevent contact between persons performing maintenance and a crane on the adjacent runway.

(b) The following precautions shall be taken before performing maintenance on a crane runway, the runway support structure, the runway conductor system, or the areas of the building in the path of travel of the crane bridge or trolley:

(1) A lockout/tagout procedure shall be performed (see para. 2-3.5.1).

(2) Warning signs and barriers shall be utilized on the floor beneath the area where overhead maintenance work creates a hazard.

(3) If the runway remains energized, stops or a signalperson(s), located full-time at a visual vantage point for observing the approach of an active crane(s), shall be provided to prohibit contact by the active crane(s) with persons performing maintenance and with equipment used in performing the maintenance.

(4) A guard or barrier shall be installed between adjacent runways for the length of any established work area to prevent contact between persons performing maintenance and a crane on the adjacent runway.

(c) Only designated persons shall work on energized equipment.

(d) After maintenance work is completed and before restoring the crane to normal operation,

(1) guards shall be reinstalled,

(2) safety devices shall be reactivated,

(3) replaced parts and loose material shall be removed, and

(4) maintenance equipment shall be removed.

2-2.3.3 Adjustments, Repairs, and Replacements

(a) Any condition disclosed by the inspections performed in accordance with the requirements of Section 2-2.1, that is determined to be a hazard to continued operation, shall be corrected by adjustment, repair, or replacement before continuing the use of the crane.

(b) Adjustments, repairs, and replacements shall be performed by designated personnel.

(c) Components shall be adjusted or repaired as needed. The following are examples:

(1) all operating mechanisms

(2) limit devices

(3) control systems

(4) brakes

(d) Repairs or replacements shall be made as needed. The following are examples:

(1) Damaged or worn hooks as described under Maintenance in ASME B30.10. Repairs by welding or reshaping are not recommended.

(2) All critical parts that are cracked, broken, bent, excessively worn, or missing.

(3) Pitted or burned electrical contacts should be corrected only by replacement and in sets. Controller parts should be lubricated as recommended in the manual supplied with the crane.

(4) Function, instruction, caution, and warning labels or plates on pendant control stations shall be kept legible.

(e) If repairs of load-sustaining members are made by welding, identification of materials shall be made and appropriate welding procedures shall be followed.

2-2.3.4 Lubrication

(a) All moving parts of the crane for which lubrication is specified should be regularly lubricated. Lubricating means should be checked for delivery of lubricant. Care should be taken to follow recommendations stated in the crane manufacturer's manual as to points and frequency of lubrication, maintenance of lubricant levels, and types of lubricant to be used.

(b) Machinery shall be stationary while lubricants are being applied, and protection provided as called for in paras. 2-2.3.2(a)(1) through (4), unless equipped for automatic or remote lubrication.

Section 2-2.4: Rope Inspection, Replacement, and Maintenance

2-2.4.1 Rope Inspection

(a) *Frequent Inspection*

(1) All ropes should be visually inspected by the

operator or other designated person at the start of each shift. These visual observations should be concerned with discovering gross damage, such as listed below, that may be a hazard.

(a) distortion of the rope, such as kinking, crushing, unstranding, birdcaging, main strand displacement, or core protrusion

(b) general corrosion

(c) broken or cut strands

(d) number, distribution, and type of visible broken wires [see paras. 2-2.4.2(b)(1) and (2) for further guidance]

(2) When such damage is discovered, the rope shall either be removed from service or given an inspection as detailed in (b) below.

(b) *Periodic Inspection*

(1) The inspection frequency shall be determined by a qualified person and shall be based on such factors as expected rope life, as determined by experience on the particular installation or similar installations; severity of environment; percentage of capacity lifts; frequency rates of operation; and exposure to shock loads. Inspections need not be at equal calendar intervals and should be more frequent as the rope approaches the end of its useful life.

(2) Periodic inspections shall be performed by a designated person. This inspection shall cover the entire length of rope. The individual outer wires in the strands of the rope shall be visible to this person during the inspection. Any deterioration resulting in appreciable loss of original strength, such as described below, shall be noted and determination shall be made as to whether further use of the rope would constitute a hazard.

(a) points listed in para. 2-2.4.1(a)

(b) reduction of rope diameter below nominal diameter due to loss of core support, internal or external corrosion, or wear of outside wires

(c) severely corroded or broken wires at end connections

(d) severely corroded, cracked, bent, worn, or improperly applied end connections

(3) Special care should be taken when inspecting sections of rapid deterioration, such as the following:

(a) sections in contact with saddles, equalizer sheaves, or other sheaves where rope travel is limited;

(b) sections of the rope at or near terminal ends where corroded or broken wires may protrude;

(c) sections subject to reverse bends; and

(d) sections of rope that are normally hidden during visual inspection, such as parts passing over sheaves.

(c) In order to establish data as a basis of judging the proper time for replacement, a continuing inspection record should be maintained. This record should cover points of deterioration listed.

2-2.4.2 Rope Replacement

(a) No precise rules can be given for determination of the exact time for rope replacement, since many variable factors are involved. Once a rope reaches any one of the specified removal criteria, it may be allowed to operate to the end of the work shift, based on the judgment of a qualified person. The rope shall be replaced after that work shift, at the end of the day, or at the latest time prior to the equipment being used by the next work shift.

(b) Removal criteria for rope replacement shall be as follows:

(1) in running ropes, twelve randomly distributed broken wires in one lay or four broken wires in one strand in one lay.

(2) one outer wire broken at the contact point with the core of the rope, which has worked its way out of the rope structure and protrudes or loops out from the rope structure.

(3) wear of one-third the original diameter of outside individual wires.

(4) kinking, crushing, birdcaging, or any other damage resulting in distortion of the rope structure.

(5) evidence of heat damage from any cause.

(6) reductions from nominal diameter greater than those listed below.

Rope Diameter	Maximum Allowable Reduction From Nominal Diameter
Up to $\frac{5}{16}$ in. (8 mm)	$\frac{1}{64}$ in. (0.4 mm)
Over $\frac{5}{16}$ in. to $\frac{1}{2}$ in. (13 mm)	$\frac{1}{32}$ in. (0.8 mm)
Over $\frac{1}{2}$ in. to $\frac{3}{4}$ in. (19 mm)	$\frac{3}{64}$ in. (1.2 mm)
Over $\frac{3}{4}$ in. to $1\frac{1}{8}$ in. (29 mm)	$\frac{1}{16}$ in. (1.6 mm)
Over $1\frac{1}{8}$ in. to $1\frac{1}{2}$ in. (38 mm)	$\frac{3}{32}$ in. (2.4 mm)

(c) Broken wire removal criteria cited in this volume apply to wire rope operating on steel sheaves and drums. The user shall contact the sheave, drum, or crane manufacturer, or a qualified person, for broken wire removal criteria for wire ropes operating on sheaves and drums made of material other than steel.

(d) Attention shall be given to end connections. Upon development of two broken wires adjacent to a socketed end connection, the rope should be resocketed or replaced. Resocketing shall not be attempted if the resulting rope length will be insufficient for proper operation.

OVERHEAD AND GANTRY CRANES

ASME B30.2-2001

(e) Replacement rope and connections shall have a strength rating at least equal to the rating of the original rope and connections specified by the hoist manufacturer. Any deviation from the original size, grade, or construction of the rope shall be specified by a rope manufacturer, the crane or hoist manufacturer, or a qualified person.

2-2.4.3 Rope Maintenance

(a) Rope should be stored to prevent damage or deterioration.

(b) Rope shall be unreeled or uncoiled in a manner to avoid inducing a twist in or kinking of the rope.

(c) Before cutting rope, means shall be used to prevent unlaying of the strands.

(d) During installation, care should be observed to avoid dragging the rope in dirt or around objects that will scrape, nick, crush, or induce sharp bends.

(e) Rope should be maintained in a well-lubricated condition. Lubricant applied as part of a maintenance program shall be compatible with the original lubricant. Lubricant applied shall be of the type that does not hinder visual inspection. Those sections of rope that are located over sheaves or otherwise hidden during inspection and maintenance procedures require special attention when the rope is being lubricated. The object of rope lubrication is to reduce internal friction and to prevent corrosion.

CHAPTER 2-3 OPERATION

Section 2-3.1: Qualifications for and Conduct of Operators

2-3.1.1 Operators of Cab-Operated and Pulpit-Operated Cranes

(a) Cranes shall be operated only by the following qualified personnel:

- (1) designated persons;
- (2) trainees under the direct supervision of a designated person; and
- (3) maintenance and test personnel, when it is necessary in the performance of their duties.

(b) No one other than personnel specified in para. 2-3.1.1(a) shall enter a crane cab or pulpit, with the exception of persons such as oilers and supervisors, whose duties require them to do so, and then only in the performance of their duties and with the knowledge of the operator or other appointed person.

2-3.1.2 Qualifications for Operators of Cab-Operated and Pulpit-Operated Cranes

(a) Operators shall be required by the employer to pass a written or oral examination and a practical operating examination unless able to furnish satisfactory evidence of qualifications and experience. Qualifications shall be limited to the specific type of equipment for which the operator is being examined.

(b) Operators and operator trainees shall meet the following physical qualifications:

- (1) have vision of at least 20/30 Snellen in one eye, and 20/50 Snellen in the other, with or without corrective lenses.
- (2) be able to distinguish colors, regardless of position of colors, if color differentiation is required for operation.
- (3) be able to hear, with or without hearing aid, adequately for a specific operation.
- (4) have sufficient strength, endurance, agility, coordination, and speed of reaction to meet the demands of equipment operation.
- (5) not have evidence of physical defects, or emotional instability that could render a hazard to the operator or others, or which, in the opinion of the

examiner, could interfere with the operator's performance. Evidence of such conditions may be cause for disqualification. In such cases, specialized clinical or medical judgments and tests may be required.

(6) not have evidence of being subject to seizures or loss of physical control. Evidence of such conditions shall be reason for disqualification. Specialized medical tests may be required to determine these conditions.

(c) Operators and operator trainees should have normal depth perception, field of vision, reaction time, manual dexterity, coordination, and no tendencies to dizziness or similar undesirable conditions.

2-3.1.3 Operators of Floor-Operated Cranes.

Cranes shall be operated only by the following qualified personnel:

- (a) designated persons;
- (b) trainees under the direct supervision of a designated person;
- (c) maintenance and test personnel, when it is necessary in the performance of their duties; and
- (d) inspectors (crane).

2-3.1.4 Qualifications for Operators of Floor-Operated Cranes. Personnel shall be required by the employer to pass a practical operating examination. Qualifications shall be limited to the specific type of equipment for which the operator is being examined.

2-3.1.5 Operators of Remote-Operated Cranes. Cranes shall be operated only by the following qualified personnel:

- (a) designated persons;
- (b) trainees under the direct supervision of a designated person;
- (c) maintenance and test personnel, when it is necessary in the performance of their duties; and
- (d) inspectors (crane).

2-3.1.6 Qualifications for Operators of Remote-Operated Cranes. The use of remote-control equipment involves such a wide variety of service requirements and conditions that each installation should be carefully analyzed and operation reviewed at least

monthly for the first 6 months of operation to determine whether para. 2-3.1.2 or 2-3.1.4 should apply.

2-3.1.7 Conduct of Operators

(a) The operator shall not engage in any practice that will divert attention while actually engaged in operating the crane.

(b) When physically or otherwise unfit, an operator shall not engage in the operation of the equipment.

(c) The operator shall:

(1) be familiar with and understand hand signals (see Fig. 10);

(2) respond to signals from the person who is directing the lift or an appointed signalperson;

(3) be responsible for the lifts when a signalperson or crane follower is not required as part of the crane operation;

(4) open the magnet switch upon request from the person on the ground, who shall wait for a signal from the operator that the magnet is deenergized; and

(5) obey a stop signal at all times, no matter who gives it.

(d) Each operator shall be responsible for those operations under the operator's direct control. Whenever there is doubt as to safety, the operator shall consult with the supervisor before handling the loads.

(e) The operator shall activate the warning device on cab- and remote-operated cranes and, when provided, on floor-operated cranes

(1) before starting the bridge or trolley motion of the crane, and

(2) intermittently during travel of the crane when approaching persons in the path of the load.

(f) Before leaving a cab-operated crane unattended, the operator shall land any attached load, place controllers in the off position, and deenergize the main switch (crane disconnect) of the specific crane. If all cranes on the runway are to be unattended for a period longer than one shift, the runway disconnect switch shall also be deenergized.

(g) The operator shall not close the main switch (crane disconnect) until certain that no worker is on or adjacent to the crane. If there is a warning sign or lock on the device, it shall not be energized until the sign or lock is removed by the person who placed it there, or by an authorized person.

(h) Before closing the main switch (crane disconnect), the operator shall be sure that all controllers are in the off position.

(i) If power goes off during operation, the operator shall immediately place all controllers in the off position.

Prior to reuse of the crane, operating motions shall be checked for proper direction.

(j) The operator shall be familiar with the equipment and its proper care. If adjustments or repairs are necessary, or any defects are known, the operator shall report the same promptly to the appointed person who shall be responsible for the operation and maintenance repairs of the crane. The operator shall also notify the next operator of any remaining uncorrected defects upon changing shifts.

(k) Contacts with runway stops or other cranes shall be made with extreme caution. The operator shall do so with particular care for the safety of persons on or below the crane, and only after making certain that any persons on the other cranes are aware of what is being done.

(l) Operators of outdoor cranes shall secure them when leaving.

(m) When the wind-indicating device of a cab-operated outdoor crane gives the alarm, crane operation shall be discontinued and the crane shall be prepared and stored for excessive wind conditions.

(n) Before the operator performs any maintenance work on the crane, the operator shall lock and tag the main switch (crane disconnect) (see para. 2-2.3.2) in the deenergized position. If the crane is equipped with a lifting magnet and the magnet is not deenergized when the main switch (crane disconnect) is in the deenergized position, the operator shall also lock and tag the magnet disconnect switch in the deenergized position.

(o) All controls shall be tested by the operator before beginning a new shift. If any controls do not operate properly, they should be adjusted or repaired before operations are begun.

(p) Persons boarding or leaving overhead cranes should do so only at authorized locations and designated boarding entrances.

(q) If the crane has more than one hoisting unit, the operator shall only lift loads, with two or more hoisting units, that are within the rated load of the crane.

Section 2-3.2: Handling the Load

2-3.2.1 Load Weight

(a) The crane shall not be loaded in excess of its rated load except for test purposes, as provided in para. 2-2.2.2, or for planned engineered lifts, as provided in para. 2-3.2.1.1.

(b) The combined load applied to more than one

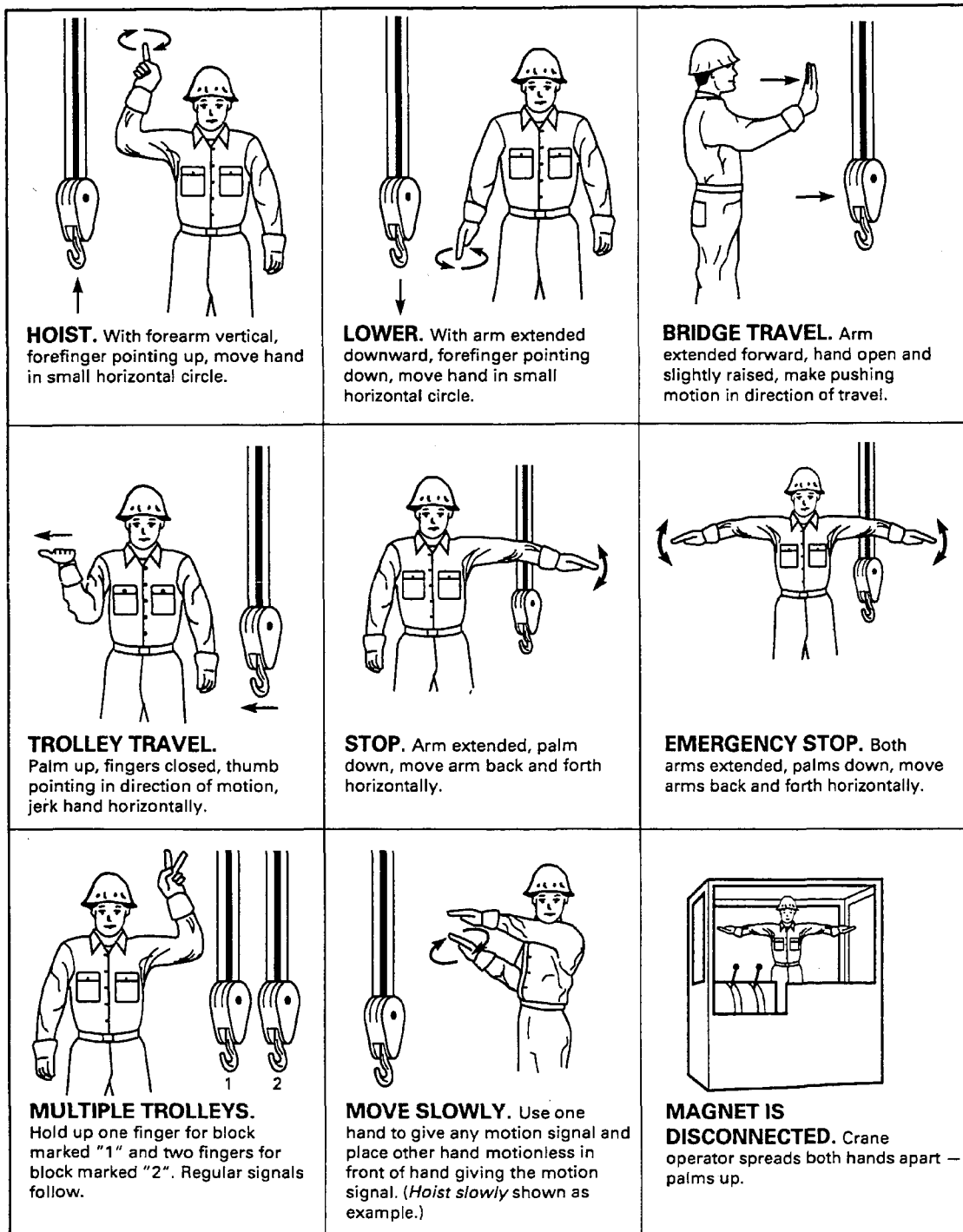

FIG. 10 STANDARD HAND SIGNALS FOR CONTROLLING OVERHEAD AND GANTRY CRANES

hoisting unit shall not exceed the rated load of the crane when the crane has more than one hoisting unit.

2-3.2.1.1 Planned Engineered Lifts. Lifts in excess of the rated load may be required from time to time on a limited basis for specific purposes such as new construction or major repairs. Every planned engineered lift exceeding the rated load shall be treated as a special and separate event.

Limitations and planned requirements shall be applicable, as follows:

(a) Planned engineered lifts shall be limited to powered cranes having a load rating of 5 tons and above.

(b) When planned engineered lifts are made, the load shall not exceed 125% of the crane load rating, except as provided in subpara. (d).

(c) Planned engineered lifts shall be limited to two occurrences on any crane within any continuous 12-month period, except as provided in subpara. (d). If greater lift frequency is desired, consideration shall be given to rerating or replacing the crane.

(d) The crane manufacturer shall be consulted if the planned engineered lift exceeds 125% of rated load or if the frequency of planned engineered lifts exceeds two during a continuous 12-month period.

(e) Each planned engineered lift shall comply with the following requirements:

(1) A written review of the crane service history shall be prepared, including reference to previous planned engineered lifts, structural repairs, and modifications of original design.

(2) The design of the structural, mechanical, electrical, pneumatic, and hydraulic components of the crane shall be reviewed, by means of applicable calculations for the load to be lifted, and approved by the crane manufacturer or a qualified person, in accordance with accepted crane design standards if the load to be lifted exceeds 125% of rated load, or if the frequency of planned engineered lifts exceeds two during a continuous 12-month period.

(3) The design of the crane-supporting structure shall be reviewed and approved by a qualified person for conformance to applicable design criteria. The crane support shall be inspected and any deterioration or damage shall be taken into consideration in design calculations for the load to be lifted.

(4) The crane shall be inspected in accordance with para. 2-2.1.3 just prior to making the lift.

(5) The lift shall be made under controlled conditions under the direction of a designated person in accordance with a previously prepared lift plan. All

persons in the area of the crane shall be alerted that the lift is being made.

(6) The operator shall test the crane at the planned engineered load by lifting the load a short distance and setting the brakes. The lift shall only be continued if the brakes stop and hold the load. Any failure to hold the load shall be corrected before proceeding with the lift.

(7) The crane shall be inspected in accordance with para. 2-2.1.3 after the lift is completed and prior to being used for the lifting of any other load.

(8) A record of the planned engineered lift, including calculations, inspections, and all distances moved, shall be placed on file for availability to appointed personnel.

(f) The rated load test specified in para. 2-2.2.2 is not applicable to planned engineered lift provisions.

2-3.2.2 Attaching the Load

(a) The hoist rope shall be free from kinks or twists and shall not be wrapped around the load.

(b) The load shall be attached to the load block hook by means of slings or other devices.

(c) Care shall be taken to make certain that the sling clears all obstacles.

2-3.2.3 Moving the Load

(a) The appointed person directing the lift shall ascertain that:

(1) the load, sling, or lifting device is seated in the bowl of the hook;

(2) the load is secured, balanced, and positioned in the hook, sling, or lifting device before the load is lifted more than a few inches (millimeters);

(3) the hoist rope is not kinked;

(4) multiple part lines are not twisted around each other;

(5) the hook is brought over the load in such a manner as to minimize swinging; and

(6) the rope is seated in the drum grooves and in the sheaves, if there is or has been a slack rope condition.

(b) During lifting, care shall be taken that:

(1) there is no sudden acceleration or deceleration of the moving load; and

(2) the load does not contact any obstructions.

(c) Cranes shall not be used for side pulls, except when specifically authorized by a qualified person who has determined that:

(1) the various parts of the crane will not be overstressed;

(2) the hoist rope will not bear or rub against

other members of the crane, such as the girders or trolley frame, except members specifically designed for such contact;

(3) such side pulls will not cause the hoist rope to be pulled out of the sheaves or across drum grooves; and

(4) such side pulls will not result in excessive swinging of the load block or load.

(d) The operator shall not cause the crane to lift, lower, or travel while anyone is on the load or hook.

(e) The operator should avoid carrying loads over people.

(f) The operator of a floor-operated crane having a lifting magnet should exercise caution due to the hazard of possible falling metal.

(g) The operator shall check the hoist brake(s) at least once each shift if a load approaching the rated load is to be handled. This shall be done by lifting the load a short distance and applying the brake(s).

(h) The load shall not be lowered below the point where two wraps of rope remain on each anchorage of the hoisting drum unless a lower-limit device is provided, in which case, no less than one wrap shall remain.

(i) When two or more cranes are used to lift a load, one qualified person shall be in charge of the operation. This person shall analyze the operation and instruct other personnel involved in the proper positioning, rigging of the load, and the movements to be made.

(j) The operator shall not leave the position at the controls while the load is suspended over an area accessible to people.

2-3.2.4 Hoist-Limit Devices (Switches)

(a) Prior to the initial use of any hoist during each shift, the operator shall verify operation of the upper-limit device under no-load conditions. If more than one upper-limit device is present, only the operation of the primary upper-limit device need be verified. Care shall be exercised; the block shall be inched into the limit or run in at slow speed. If the device does not operate properly, the operator shall immediately notify the appointed person.

(b) The hoist-limit device that controls the upper limit of travel of the load block shall not be used as an operating control in normal operation unless additional means are provided to prevent damage from overtravel.

Section 2-3.3: Signals

2-3.3.1 Standard Signals

(a) Signals to the operator shall be in accordance

with this volume, unless voice communication (telephone, radio, or equivalent) is utilized.

(b) Signals should be discernible or audible to the operator.

(c) Hand signals shall be posted conspicuously and should be as illustrated in Fig. 10.

2-3.3.2 Special Signals

(a) Special operations may require additions to or modifications of standard signals.

(b) Special signals shall be agreed upon and understood by the signalperson and the operator.

(c) Special signals shall not conflict with standard signals.

Section 2-3.4: Miscellaneous

2-3.4.1 Ladders

(a) Hands shall be free from encumbrances while personnel are using ladders.

(b) Articles that are too large to be carried in pockets or tool belts shall be lifted and lowered by hand line.

2-3.4.2 Cabs

(a) Necessary clothing and personal belongings shall be stored in a manner that does not interfere with access or operation.

(b) Tools, oil cans, rags, and other necessary articles shall be stored in a fire-resistant container and shall not be permitted to lie loose in or around the cab.

2-3.4.3 Fire Extinguishers. Operators shall be familiar with the location, operation, and care of fire extinguishers provided (see para. 2-1.5.5).

Section 2-3.5: Crane Lockout/Tagout

2-3.5.1 General

(a) A lockout/tagout policy and procedure shall be developed, documented, and implemented by the owner or user of overhead cranes.

(b) The lockout/tagout policy and procedure shall comply with the requirements of ANSI Z244.1.

(c) The policy shall give consideration to the following areas:

- (1) single-crane runways
- (2) multiple-crane runways
- (3) cranes on an adjacent runway
- (4) runway disconnecting means
- (5) crane disconnecting means

OVERHEAD AND GANTRY CRANES

ASME B30.2-2001

- (6) work to be done on a crane
- (7) work to be done other than on a crane but within the path of a crane where its movement creates a hazard.

ASME B30.2 INTERPRETATIONS

**Replies to Technical Inquiries
September 2000 – October 2001**

FOREWORD

This publication includes all of the written replies issued between the indicated dates by the Secretary, speaking for the ASME B30 Committee, Safety Standards for Cableways, Cranes, Derricks, Hoists, Hooks, Jacks, and Slings, to inquiries concerning interpretations of technical aspects of B30.2, Overhead and Gantry Cranes (Top Running Bridge, Single or Multiple Girder, Top Running Trolley Hoist).

These replies are taken verbatim from the original letters except for a few typographical corrections and some minor editorial corrections made for the purpose of improved clarity. In some few instances, a review of the interpretation revealed a need for corrections of a technical nature; in these cases, a corrected interpretation follows immediately after the original reply.

These interpretations were prepared in accordance with the accredited ASME procedures. ASME procedures provide for reconsideration of these interpretations when or if additional information is available which the inquirer believes might affect the interpretation. Further, persons aggrieved by this interpretation may appeal to the cognizant ASME Committee or Subcommittee. ASME does not "approve," "certify," "rate," or "endorse" any item, construction, proprietary device, or activity.

Interpretation: 2-47

Subject: ASME B30.2b-1998

Date Issued: December 10, 1999

Question (1): Paragraph 2-1.5.3 indicates that "access to the cab or bridge walkway shall be by a fixed ladder, stairs, or platform. The ladder shall be in conformance with ANSI A14.3, except as modified to meet the requirements of this volume."

Paragraph 2-1.7.2(c) states: "Ladders shall be fastened in place and shall be constructed in compliance with ANSI A14.3, except as modified to meet the requirements of this volume."

Our cranes, built in 1974, are accessed by means of pull-down ladders. The ladders were provided by the original equipment manufacturer and have had a safe record of use in our plant. A safety interlock is included, which prevents crane motion when the ladder is not fully raised. An over-counterweight keeps the ladder retracted. The ladder is 12 in. wide with 250 lb as a limit.

Nowhere is a reference made to the acceptability of pull-down ladders as a means of cab access from the floor. Does a pull-down ladder meet the intent of the B30.2 volume?

Reply (1): Paragraph 2-1.5.3, Access to Crane, applies to means external to the crane that allows the crane operator or other personnel to gain access to the cab or bridge.

Paragraph 2-1.7.2, Ladders and Stairways, applies to ladders and stairways that are an integral part of the crane structure that allow the crane operator or other personnel to gain access between levels of the crane.

When designed in accordance with applicable standards, a pull-down ladder could be part of the external means to gain access to the crane, or to gain access to different levels of the crane. An integral pull-down ladder from the crane to gain direct access from the floor does not meet the basic intent of ASME B30.2; however, when designed in accordance with applicable standards and with provisions that take into account possible hazards associated with a ladder that allows direct access to the cab from the floor, such a ladder could fall under the exception clause of para. 2-1.5.3.

Question (2): Does a pull-down ladder meet the intent of the standards, particularly as they may apply to fall protection and prevention?

Reply (2): See Reply (1). The B30.2 volume does not address fall protection or fall prevention. This subject is covered by other standards. The B30 Committee cannot issue a reply to subjects not covered or addressed in any specific B30 volume.

Interpretation: 2-48

Subject: ASME B30.2b-1998

Date Issued: December 10, 1999

Question (1): Would the following practice suffice under the guidelines prescribed by para. 2-2.1.2? During the course of operation of an overhead traveling crane, it is discovered that the hoist limit switch is malfunctioning. The auxiliary crane servicing that area has been taken out of service for repairs; therefore, the operation of the said crane has been necessitated.

The determination was made to double-man the crane by utilizing the Crane Operator from the other crane as a Spotter. He was instructed to visually insure that the other Operator did not lift any loads into the limit switch. The potential hazard was deemed minimal since there was no need to hoist the block in to close proximity of the limit switch.

Side notes to this issue are as follows:

- (a) Pre-shift tests of limit switches are performed by Crane Operators.
- (b) The double-manning was halted after repairs were made to the back-up crane.
- (c) The limit switch was then repaired to the primary crane.

Reply (1): Paragraph 2-2.1.2, Frequent Inspection, states the following:

- (a) Frequent inspection shall include observations during operation.
- (b) A designated person shall determine whether conditions found during the inspection constitute a hazard and whether a more detailed inspection is required.
- (c) The following items shall be inspected:
 - (1) operating mechanisms for proper operation, proper adjustment, and unusual sounds;
 - (2) upper limit device(s) in accordance with para. 2-3.2.4(a);
 - (3) tanks, valves, pumps, lines, and other parts of air or hydraulic systems for leakage;
 - (4) hooks and hook latches (if used) in accordance with ASME B30.10;
 - (5) hoist ropes and end connections in accordance with para. 2-2.4.1(a); and
 - (6) rope for proper spooling onto the drum(s) and sheave(s).

Paragraph 2-3.2.4, Hoist Limit Devices (Switches), and subparagraph (a) state the following:

Prior to the initial use of any hoist during each shift, the operator shall verify operation of the upper-limit device under no-load conditions. If more than one upper-limit device is present, only the operation of the primary upper-limit device need be verified. Care shall be exercised; the block shall be inched into the limit or run in at slow speed. If the device does not operate properly, the operator shall immediately notify the appointed person.

In Chapter 2-1, General Construction and Installation, para. 2-1.13.5(d) states the following:

Power-driven hoists shall be designed and constructed so that the load block, either loaded or empty, shall not exceed the upper limit of travel. On wire-rope hoists, if a geared or other limit switch or device that operates in relation to drum turns is used, an additional limit switch or device that operates independent of drum rotation shall be provided.

The word *shall* is defined in Section 2-0.2, Definitions, as follows:

shall: this word indicates that a rule is mandatory and must be followed.

Requirements as stated in the referenced sections or paragraphs, with the use of the word *shall*, means that an upper-limit device or switch must be functional for the crane to be in compliance with B30.2. The B30.2 volume does not address means for crane operation when a major safety device, such as an upper-limit device or switch is not functional. Therefore, the method you described does not meet the requirements of the B30.2 volume.

Interpretation: 2-49

Subject: ASME B30.2-1996

Date Issued: May 30, 2001

Question (1): When we start our refueling outage we do a complete periodic inspection of the crane and this inspection is performed 2 days to a week before any planned engineering lift is made. The crane is being used after the inspection and prior to the planned engineering lift. In para. 2-3.2.1.1(e)(4) what does "just prior to" mean? Does it mean immediately before the lift or just anytime prior to the lift, even though the crane has been in use after the inspection and prior to the planned engineered lift?

Reply (1): Paragraph 2-3.2.1.1(e)(4), in using the phrase "just prior to," does not place a time frame between the inspection and the planned engineered lift. It does mean that the crane is not to be used for any other lifting purposes between the time of the inspection and the time of the planned engineered lift.

Question (2): If the answer to the first question is "just anytime prior to making the lift," would the post/after lift inspection serve as the pre-inspection for a second planned engineered lift of the same piece of equipment that occurs a few weeks later?

Reply (2): No reply is necessary. However, your attention is directed to para. 2-3.2.1.1(c) regarding occurrences of planned engineered lifts.

ISBN 0-7918-2728-3



9 780791 827284



J08901